

ENGINEERED BAR SYSTEMS

Marine Tie Bars
Architectural Bar Systems
Post Tensioning Bars



Dextra

www.dextragroup.com

About us

Established in 1983, Dextra Manufacturing is an ISO and ASME-certified leading manufacturer and distributor of engineered construction products for the building and civil industries.

For over fifteen years Dextra had been selling a comprehensive range of steel bar systems suitable for a variety of concrete, ground engineering and structural steelwork applications.

The combination of our in-house engineering expertise and design capability with modern manufacturing facilities has allowed us to supply major construction projects such as Boubiyah Seaport (6,000 tons of Tie rods and accessories), Suvarnabhumi International Airport in Bangkok (2,000 tons of tension bars) and Jaber Causeway-Doha Link in Kuwait (1,750 tons of post-tensioning bar systems).

Content

Our Expertise

Marine Tie Bars

Architectural Bar Systems

Carbon Steel Tension Rods

Stainless Steel Tension Rods

Compression Struts

Post Tensioning Bars

Smooth Bars Systems

Shear Key Systems

Fully Threaded Systems

Our Expertise

Identification of need

DETERMINATION OF THE RIGHT SOLUTION

Dextra can guide you step-by-step in selecting the most appropriate and cost effective solution for your project. Our guidance is based on 30 years of experience in managing large-scale & complex projects.

Design & Engineering

SYSTEM OPTIMIZATION AND CUSTOMIZATION

Dextra has developed over the years a comprehensive standard range of components that allows the quick adjustment and customization of our products for a truly optimized project solution. Our team will support in the selection and drawing of your systems.

For designers, Dextra offers full technical documentation as well as design/drafting software components. These can be found in the download section of www.dextragroup.com.

Manufacturing & Quality

TOTAL CONTROL OVER MANUFACTURING

Dextra operates its own manufacturing and testing facilities, which are located in Bangkok. The factory is supported by fully ISO-certified quality assurance processes. All suppliers are also regularly audited by a team of engineers in order to ensure quality compliance and drive continuous improvement. Inspections prior to delivery are arranged at Dextra's factory, or in partner laboratories when required.

Packing and Logistics

PACKING & SHIPPING

Dextra prides itself to only provide the best packing solution for all exported goods to ensure safe shipping and flawless deliveries. Each bar system component is individually marked to allow easy and quick identification and save time upon installation.

When time is an issue, Dextra can offer acceleration schemes to expedite our solutions in order to prevent site delays.

Installation & Testing

ON-SITE SERVICE & SUPPORT

Dextra team knows that product delivery is only one more step in your project. Our experts are also available to provide assistance during installation phase as required.



Marine Tie Bars



Marine Tie Bars

About our range

Tie Bars are used in port and harbour construction to anchor waterfront structures. Steel grades from 355 to 700 N/mm² in yield strength, and thread diameters from M48 to M162.

Different standard designs of articulated joint are available, including swivel plates, captive nuts and ball cages, to ensure the project requirements are fully accommodated.

Anchorage can be made compatible with all sheet pile profiles, combi walls and concrete diaphragm walls.

For projects using sheet piles, Dextra can also design and prefabricate waling beam systems with waling bolts to provide a complete anchoring system which will ensure full compatibility and consistency with our tie bars systems.

Product features

- Available in steel grades 355/510, 500/600, 700/900 N/mm².
- Thread diameter range M48 to M162.
- Rolled threads for better fatigue performance.

Typical applications

- Harbors
- Wharves
- Jetties
- River embankments
- Container terminals
- Oil & Gas terminals

Product benefits

- Ductile design.
- Quick installation.
- Full range of accessories and corrosion protection options.
- Post-tensioning applicable.

Corrosion protection / surface finish

Various corrosion protection options are available such as bituminous tape, epoxy coating, sacrificial thickness depending on the project design and requirements.

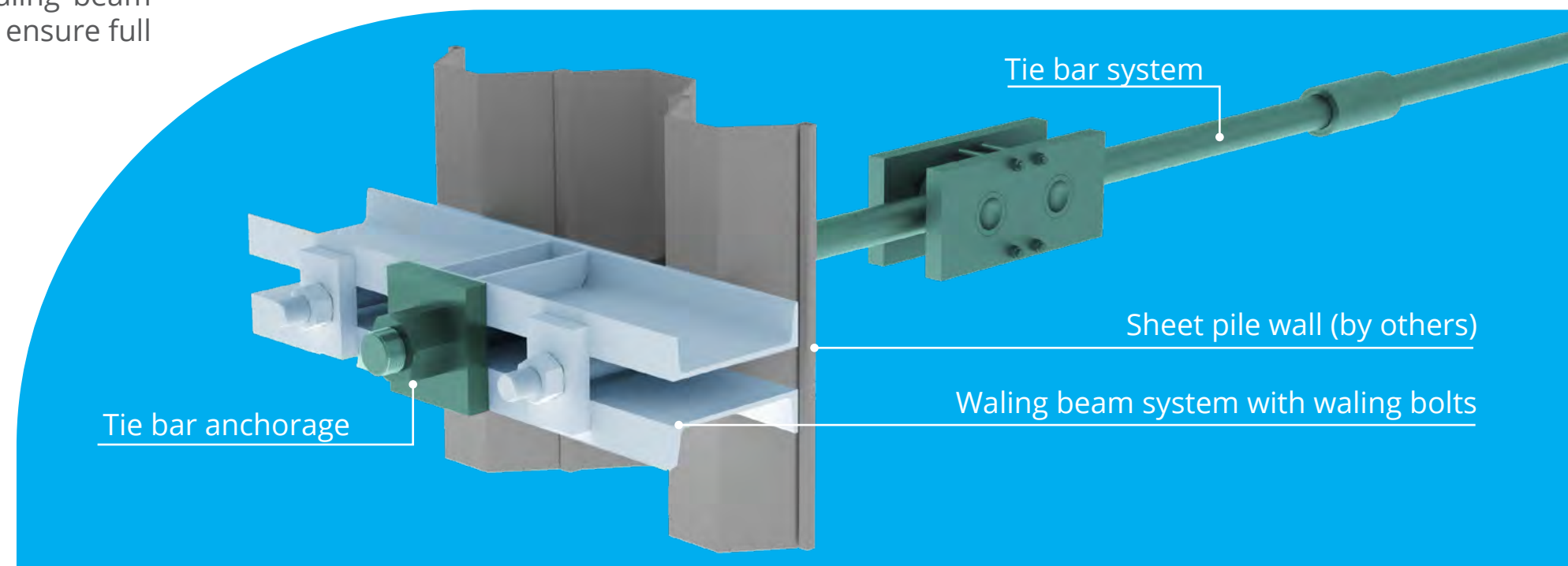

Load Capacity

Thread size	Grade 355/510			Grade 500/660			Grade 700/900		
	Un-factored Yield Load	Un-factored Ultimate Load	Tension Capacity as per EC3*	Un-factored Yield Load	Un-factored Ultimate Load	Tension Capacity as per EC3*	Un-factored Yield Load	Un-factored Ultimate Load	Tension Capacity as per EC3*
mm	kN	kN	kN	kN	kN	kN	kN	kN	kN
M48	523	751	541	737	972	700	1,031	1,326	955
M52	624	896	645	879	1,160	835	1,230	1,582	1,139
M56	721	1035	745	1,015	1,340	965	1,421	1,827	1,315
M60	839	1205	867	1,181	1,559	1,122	1,653	2,126	1,531
M64	950	1365	983	1,338	1,766	1,272	1,873	2,408	1,734
M68	1085	1558	1122	1,528	2016	1,452	2,139	2,750	1,980
M72	1228	1764	1270	1,730	2,283	1,644	2,422	3,114	2,242
M78	1460	2098	1510	2,057	2,715	1,955	2879	3,702	2,666
M83	1669	2398	1726	2,351	3,103	2,234	3,291	4,231	3,047
M88	1892	2718	1957	2,664	3,517	2,532	3,730	4,796	3,453
M93	2128	3058	2202	2,998	3,957	2,849	4,197	5,396	3,885
M98	2379	3418	2461	3,351	4,423	3,184	4,691	6,031	4,342
M103	2643	3798	2734	3,723	4,915	3,539	5212	6,702	4,825
M108	2922	4198	3022	4,115	5,432	3,911	5,762	7,408	5,334
M113	3214	4618	3325	4,527	5,976	4,303	6,338	8,149	5,867
M118	3521	5058	3642	4,959	6545	4,713	6,942	8,926	6,426
M123	3841	5518	3973	5,410	7,141	5,141	7,574	9,738	7,011
M128	4175	5998	4319	5,881	7,762	5,589	8,233	10,585	7,621
M133	4523	6498	4679	6,371	8,410	6,055	8,919	11,468	8,257
M143	5261	7559	5442	7,411	9,782	7,043	10,375	13,339	9,604
M153	6055	8699	6263	8,529	11,258	8,106	11,940	15,352	11,053
M162	6818	9794	7052	9,602	12,675	9,126	13,443	17,284	12,444

* Loads as per EN 1993-5 (Eurocode 3) considering $k_t=0.9$ as permitted when rotation is possible at anchorages.

System Presentation

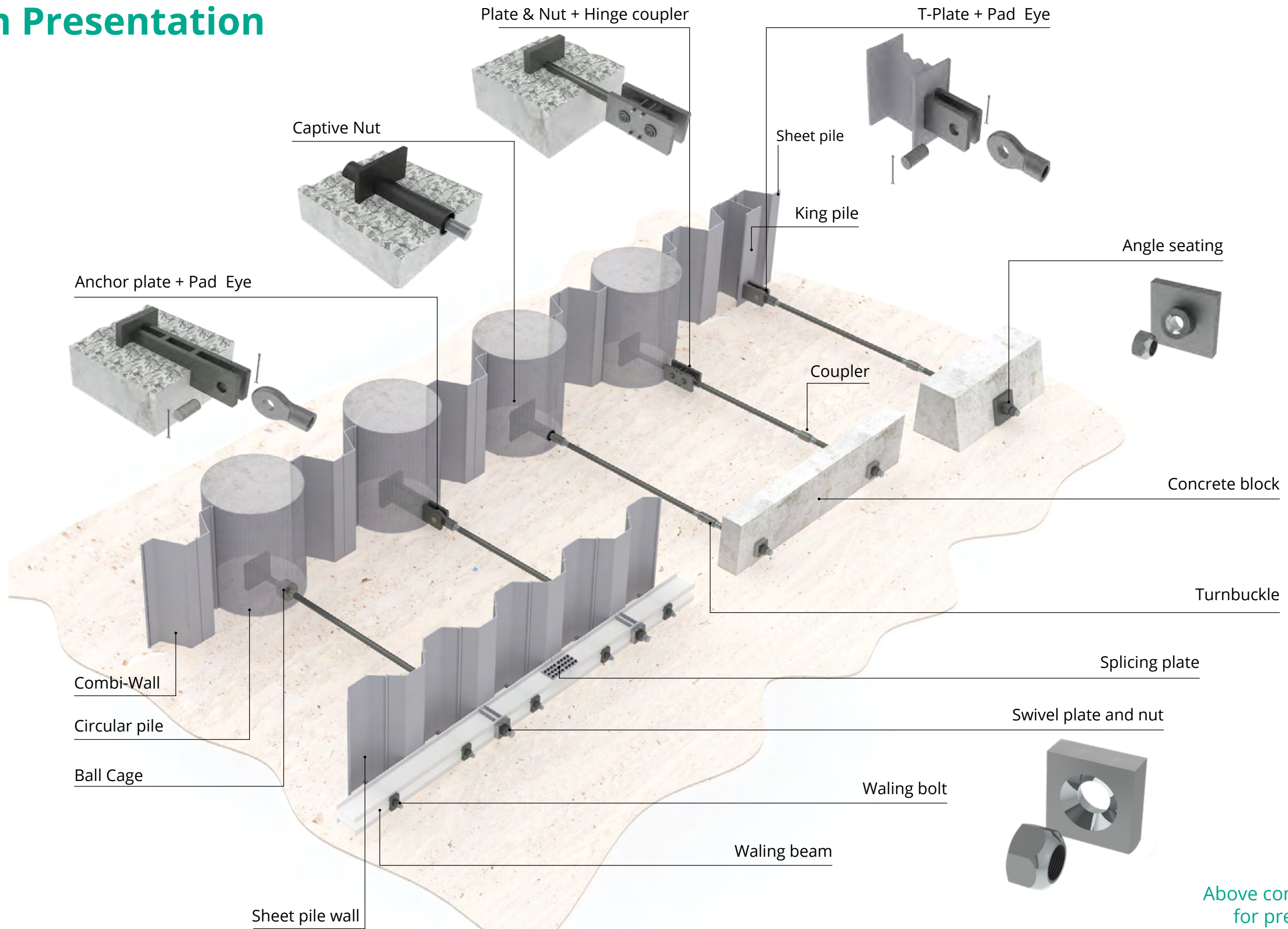

Above combination of accessories for presentation purpose only.

Type of walls and compatibility

	Wall element	Captive Nut	Ball Cage	Hinge Coupler	Anchor Plate	T-Plate	Swivel plate	Swivel Angle Seating
	Additional accessory on bar end	-	Plate & Nut	Plate & Nut	+ Pad Eye	+ Pad Eye	+ Swivel Nut	+ Swivel Nut
	Rotation capability	5°	± 10°	45°	± 90°	± 90°	± 7°	± 7°
	Directions	all	all	vertical	vertical	vertical	all	all
Steel wall	Sheet Pile + Waling beam						X	X
	HZ Pile (King Pile)					X		
Concrete wall	Circular Pile / Combi-Wall	X	X	X	X			
	Concrete Capping Beam	X	X	X	X			
	Diaphragm Wall	X	X					
	Concrete Block			X			X	X



Resources



Brochure



Datasheet



Webpage

Project References



Maitree Super Thermal Power, Bangladesh



Sète Port, France



Port Autonome De Pointe-Noire, Republic of the Congo



MultiRio Container Terminal, Brazil

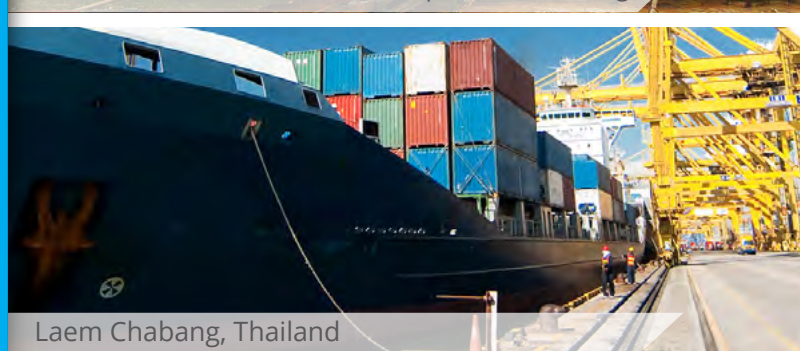

Laem Chabang, Thailand

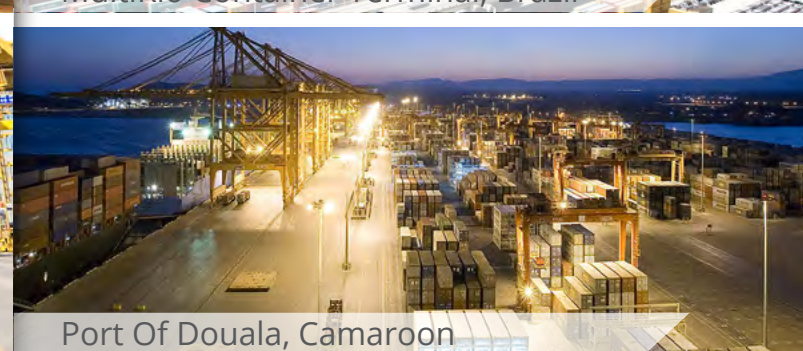

Port Of Douala, Cameroon

CAD & BIM Tools



Connect with us



www.dextragroup.com





Architectural Bar Systems

[About Us](#)

[Our Expertise](#)

[Marine Tie Bars](#)

[Architectural Bar Systems](#)

[Post Tensioning Bars](#)



Architectural Bar Systems

About our range

Tension Rods typically act as bracing or suspension elements and provide the benefits of high strength, length adjustability, ease of installation as well as the ability to be post-tensioned after installation.

Compression struts complement the range of architectural bar systems and are used when structural members are required to take compression loads as well as having the benefits of installation and aesthetic appeal associated with the Dextra tension rod system.

A wide range of sizes and accessories in various steel grades and in both carbon and stainless steel is available.

Typical applications

- Roof support systems
- Hanging floors
- Canopies roof support systems
- Road and pedestrian bridges
- Truss bracing systems
- Temporary stays and braces



AUTODESK
AUTOCAD



AUTODESK
REVIT

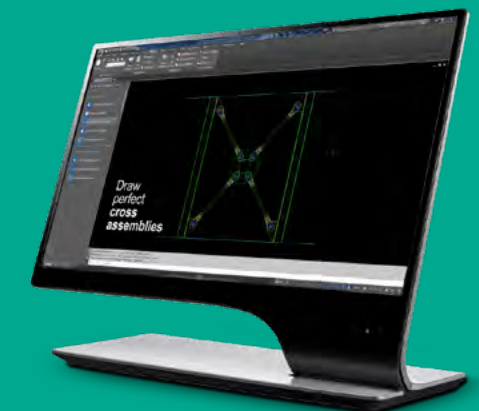
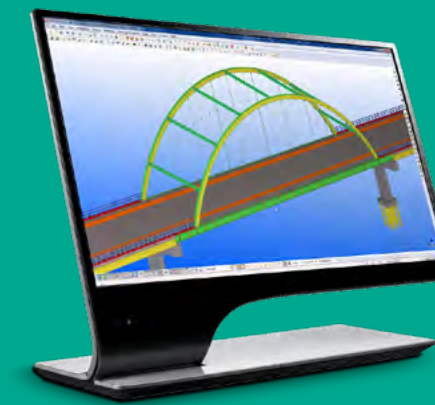

CAD & BIM

Structures incorporating architectural tension bar systems are often complex.

To aid in the design, detailing and installation, Dextra offers automated drawing components in AutoCAD (2D), Trimble Tekla Structures (3D) and Revit (3D).

Carbon steel



Design references

BS EN 1993 (Eurocode 3)

Product features

- Available in steel grades 460, 520 & 700 N/mm²
- Thread diameter range M16 to M133.
- Rolled threads for better performance.

Surface finish

Carbon Steel Tension Rods can either be delivered epoxy painted or galvanized. If required, they can also be delivered unpainted (plain black steel surface).

About our carbon steel range

Available in high strength grades, allowing the use of smaller diameters to achieve the same tension capacity as larger diameter mild steel tension bars.

In situ length adjustment can be achieved by rotation of the bar into the forks and/or at each turnbuckle along the tendon.

Turnbuckles also allow for the application of a preload, making for example self-weight sagging corrections easier.



Accessories

<p>Forks and Spades</p>		<p>To be connected to grade S355 gusset plates. They can also be connected together to form an articulation joint.</p>
<p>Couplers</p>		<p>To connect individual lengths of bar, usually to achieve a greater tendon length than is possible with a single bar.</p>
<p>Turnbuckles</p>		<p>To connect bars and adjust the overall tendon length.</p>
<p>Cross Turnbuckles</p>		<p>To allow two tendons to cross each other in the same plan.</p>
<p>Lock covers</p>		<p>To cover the exposed thread of the bar and prevent the relative rotation of components.</p>

Fork

Coupler and lock covers

Turnbuckle and lock covers

Spade

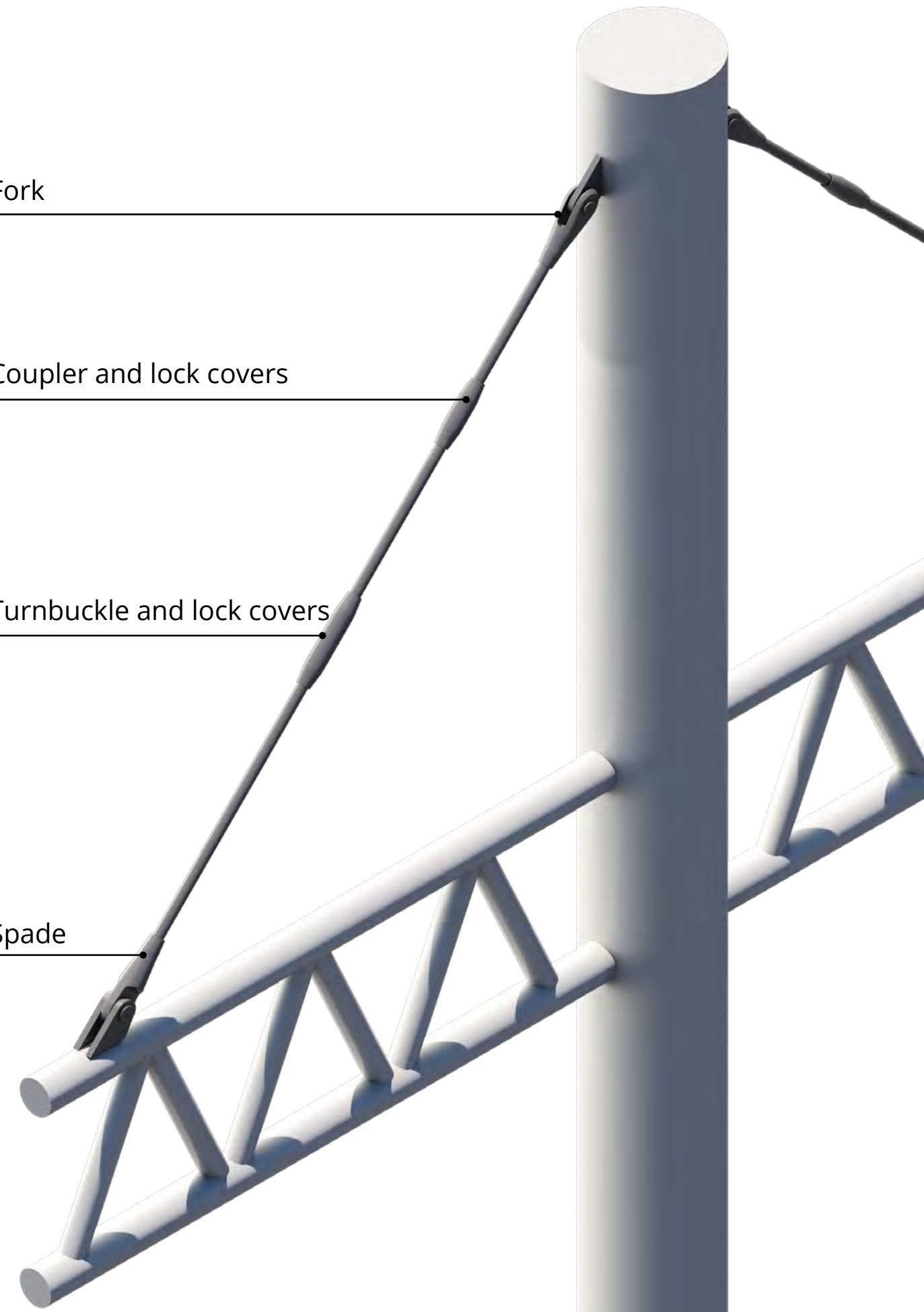

Carbon steel systems load table

Rod Thread Size	Nominal Rod Ø*	Rod Critical Section	Rod Linear Weight	Grade 460			Grade 520			Grade 700		
				Yield Load**	Ultimate Load**	Tension Capacity as per EC3***	Yield Load**	Ultimate Load**	Tension Capacity as per EC3***	Yield Load**	Ultimate Load**	Tension Capacity as per EC3***
mm	mm	mm ²	kg/m	kN	kN	kN	kN	kN	kN	kN	kN	kN
M16	15	157	1.4	72	98	71	81	105	76	110	141	102
M20	19	245	2.2	113	153	110	127	164	118	171	220	159
M24	23	353	3.3	162	220	159	183	236	170	247	317	228
M30	28	561	4.8	258	350	252	292	376	270	392	505	363
M36	34	817	7.1	376	510	368	425	547	394	572	735	529
M42	40	1121	9.9	516	701	504	583	751	541	785	1009	726
M48	45	1473	12.5	678	921	663	766	987	711	1031	1326	955
M52	49	1758	14.8	809	1099	791	914	1178	848	1230	1582	1139
M56	53	2030	17.3	934	1269	914	1056	1360	979	1421	1827	1315
M64	61	2676	22.9	1231	1672	1204	1392	1793	1291	1873	2408	1734
M68	65	3055	26.0	1405	1910	1375	1589	2047	1474	2139	2750	1980
M78	75	4114	34.7	1892	2571	1851	2139	2756	1984	2879	3702	2666
M83	80	4702	39.5	2163	2938	2116	2445	3150	2268	3291	4231	3047
M88	85	5329	44.5	2451	3331	2398	2771	3570	2571	3730	4796	3453
M93	90	5995	49.9	2758	3747	2698	3118	4017	2892	4197	5396	3885
M98	95	6701	55.6	3083	4188	3016	3485	4490	3233	4691	6031	4342
M103	100	7446	61.7	3425	4654	3351	3872	4989	3592	5212	6702	4825
M113	110	9054	74.6	4165	5659	4075	4708	6066	4368	6338	8149	5867
M123	120	10820	88.8	4977	6762	4869	5626	7249	5219	7574	9738	7011
M133	130	12742	104.2	5861	7964	5734	6626	8537	6147	8919	11468	8257

*Nominal bar diameter may vary for small order quantities ** Yield and ultimate loads are unfactored *** As per BS EN 1993-1-1 γ_{m0} 1.0; γ_{m2} 1.25

Stainless steel



Design references

BS EN 1993 (Eurocode 3)

Surface finish

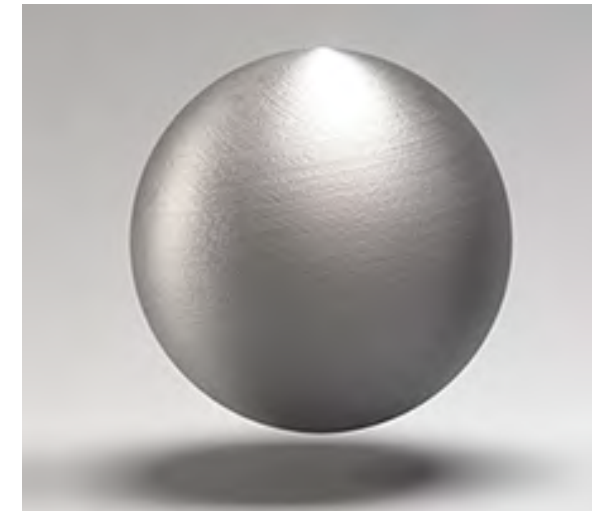

Satin finish
Ra 0.4 (N5) as per ISO 1302

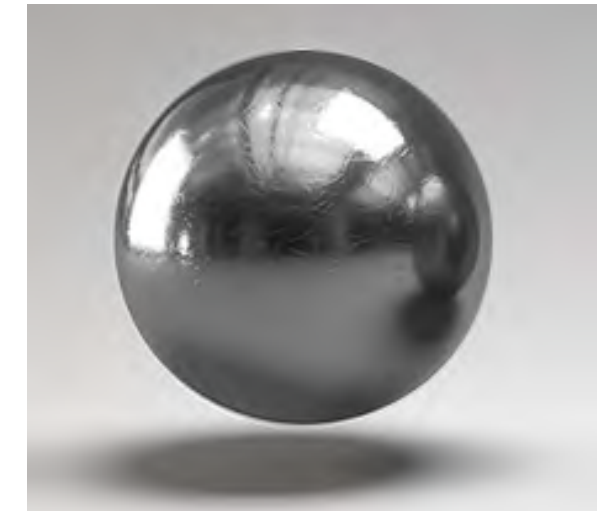

Mirror finish
Ra 0.1 (N3) as per ISO 1302
(Available upon request)

About our stainless steel range

When the requirements for pleasing aesthetics or corrosion protection are particularly high, stainless steel tension rods are the perfect solution.

Product features

- Available in stainless steel grade S460 & S520.
- Thread diameter range M16 to M98.
- Rolled threads.



Stainless steel systems load table

Rod Thread Size	Nominal Rod Ø*	Rod Critical Section	Rod Linear Weight	Grade S460			Grade S520		
				Yield Load**	Ultimate Load**	Tension Capacity as per EC3***	Yield Load**	Ultimate Load**	Tension Capacity as per EC3***
mm	mm	mm ²	kg/m	kN	kN	kN	kN	kN	kN
M16	15	157	1.4	72	102	73	81	105	76
M20	19	245	2.3	113	159	115	127	164	118
M24	23	353	3.3	162	229	165	183	236	170
M30	28	561	4.9	258	364	257	292	376	270
M36	34	817	7.2	376	531	380	425	547	394
M42	40	1121	10.0	516	729	525	583	751	541
M48	45	1473	12.7	678	958	665	766	987	711
M56	53	2030	17.6	934	1320	923	1056	1360	979
M64	61	2676	23.3	1231	1739	1222	1392	1793	1291
M78	75	4114	35.2	1892	2674	1847	2139	2756	1984
M83	80	4702	40.1	2163	3056	2102	2445	3150	2268
M88	85	5329	45.2	2451	3464	2373	2771	3570	2571
M93	90	5995	50.7	2758	3897	2660	3118	4017	2892
M98	95	6701	56.5	3083	4356	2964	3485	4490	3233

* Nominal bar diameter may vary for small order quantities

** Yield and ultimate loads are unfactored

*** As per BS EN 1993-1-4 γ_{m0} 1.1; γ_{m2} 1.25

Compression Struts



Design references

BS EN 1993 (Eurocode 3)

Product features

- Struts are available in two alternative designs:
 - Architectural (with long cone and smoother lines).
 - Non-architectural.
- Carbon steel tube (Circular Hollow Section) range from 42mm to 324mm.
- Thread diameter range from M16 to M103.
- Length adjustment of the assembly possible at each fork end.

Typical applications

- Roof support
- Truss bracing
- Face bracing

Surface finish

Compression struts can either be delivered painted or galvanized. If required, they can also be delivered unpainted (plain black steel surface).

Architectural strut

Non-Architectural strut

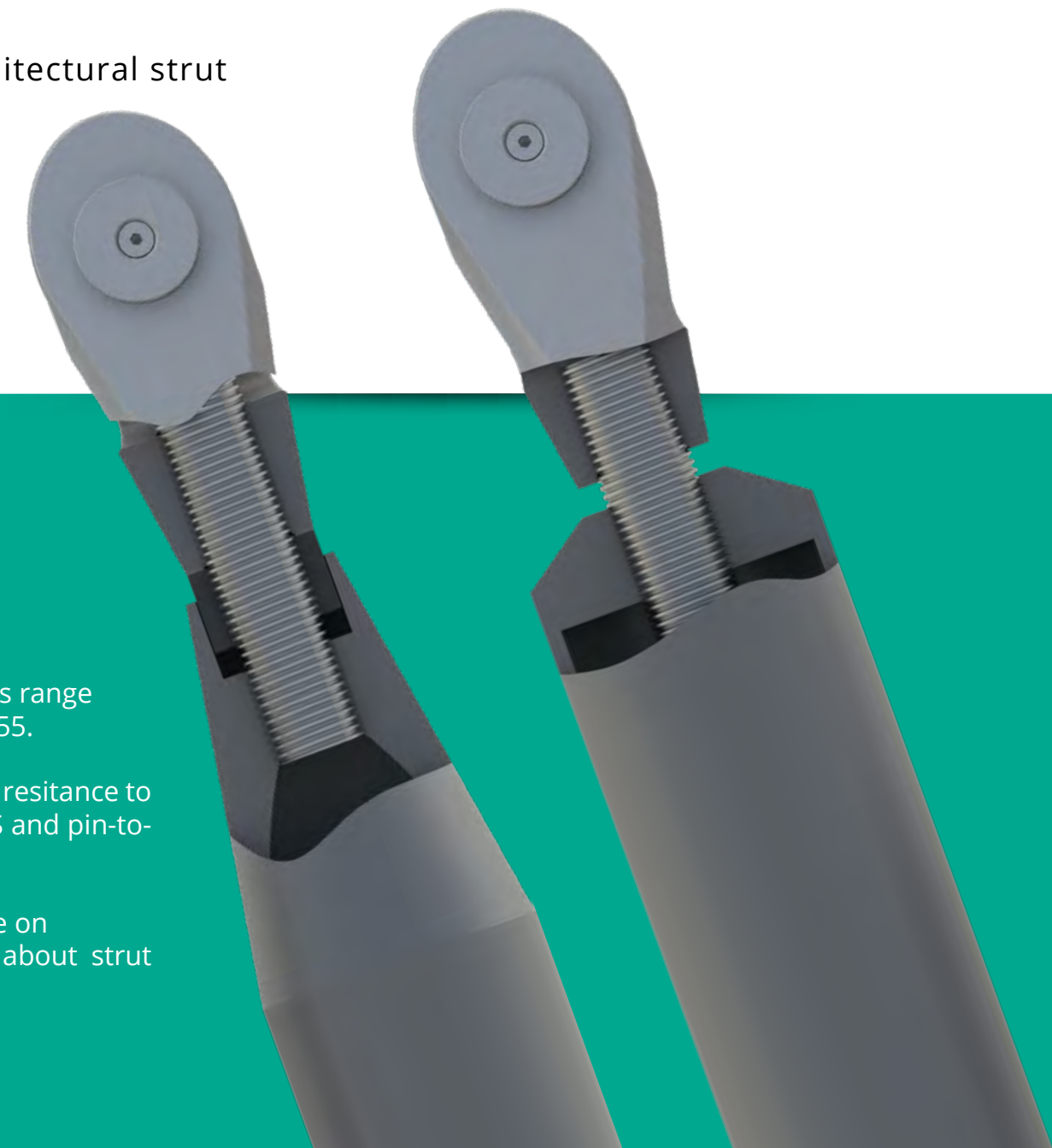

Model selection

CHS (circular hollow section) compression struts range from M30 to M103 and are available in grade 355.

The total compression capacity is limited by the resistance to buckling (which depends on the size of the CHS and pin-to-pin length).

Please refer to the technical datasheet available on www.dextragroup.com for more information about strut selection.



Resources



Brochure



Datasheet



Webpage



Certification

Project References

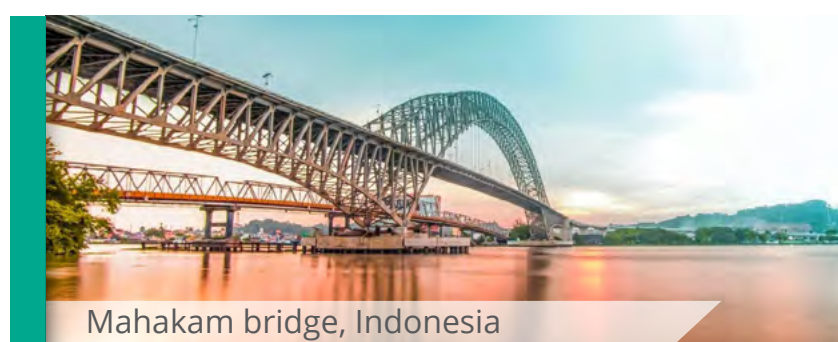

Mahakam bridge, Indonesia

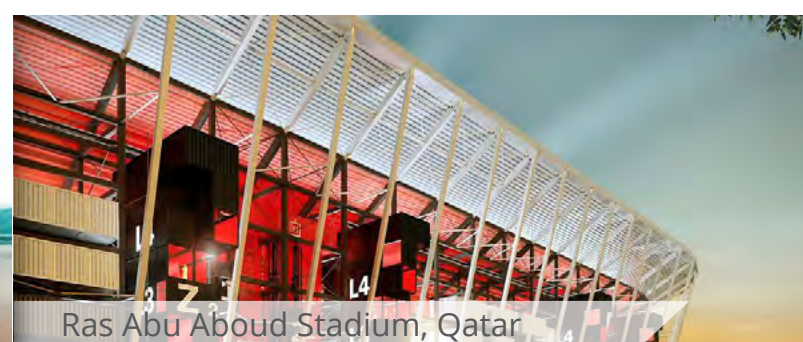

Ras Abu About Stadium, Qatar



Cylingas Reservoirs, UAE

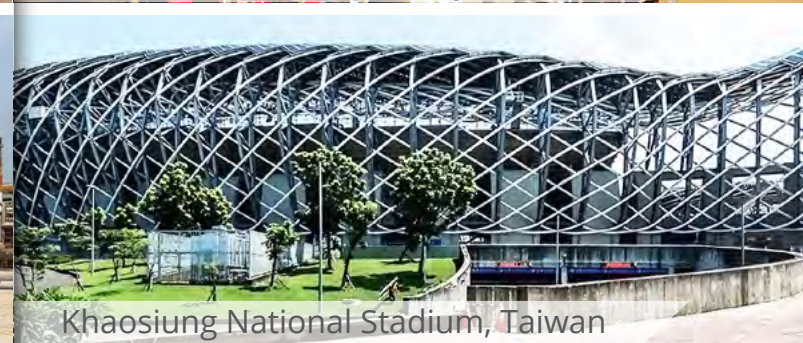

Khaosung National Stadium, Taiwan



Abu Dhabi International Airport, UAE



Suvarnabhumi International Airport, Bangkok

CAD & BIM Tools



Connect with us



A photograph of a construction site featuring a large concrete structure under development. The structure is supported by a complex network of blue metal scaffolding. The background shows a clear blue sky and some greenery. The overall image has a blue tint.

Post Tensioning Bar Systems



Post Tensioning Bar Systems

About our range

For permanent works such as connecting various segments of bridge structures, shear keys for seismic resistance, connection of segments or girders and the reinforcement of piers.

For temporary works such as the anchoring of temporary steel frame supports, lifting bars for segment launching trusses, and stitching bridge segments.

The Dextra post-tensioning range features both **fully-threaded bars** and **smooth bars**, with a full range of accessories.

The services of a fully dedicated design team are available to provide engineering support.

Corrosion protection

Various corrosion protection measures are available depending on whether the tendon is temporary, permanent, bonded, un-bonded and with or without free un-bonded length.

Protection can be achieved by the application of a heat shrink sleeve, grease, paint, grout, or a combination of these.

The smooth bars for shear key applications are normally supplied in a HDPE tube injected with grease and complete with specially designed accessories.

Typical applications

- Post-tensioning of concrete structures.
- Temporary bracing / Temporary post-tensioning.
- Heavy lifting.
- Seismic restrainer system.
- Hold down for steel structure, wind turbine.
- Structural steel frame ties.
- Bridge segment connections.
- Bridge segment continuity tendons.
- Pre-stressed concrete.
- Pile-testing.

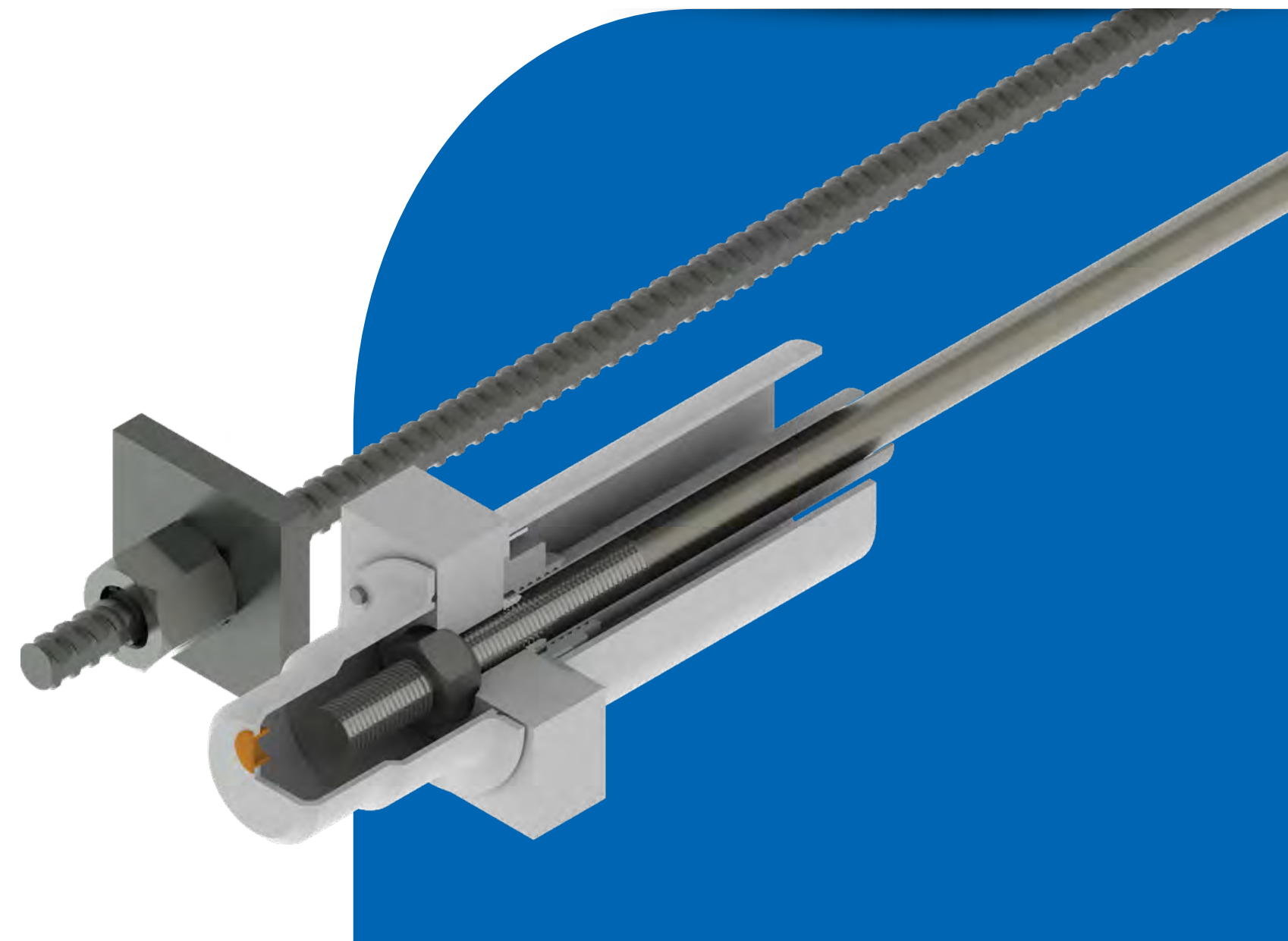

Smooth bar range



Design references

- AASHTO
- Eurocode 2

About our range

- High impact resistance.
- Smaller pitch allows finer adjustment and brings less draw-in loss.
- Full range of accessories for specific applications.
- High fatigue performance.

Product features

- Diameter range from 31 mm to 100 mm.
- Three steel grades available.
 - › Gr 835/1030
 - › Gr 930/1080
 - › Gr 1050/1200
- Rolled threads (obtained with cold plastic deformation of the metal between two dies) optimized for fatigue performance.
- ISO metric thread as per ISO 965-1.

Special application: Shear key & Hold down bar systems

- Shear key and hold down bars are a special application of PT smooth bar systems where an assembly acts as a permanent seismic restrainer for the connection of precast elements (e.g. for elevated metro road).
- Shear key bar systems and hold down bar systems are available with a full range of accessories for grade 1050/1200 and in four diameters: 37/M39, 43/M45, 45/M48 and 49/M52.



Shear key bar

Hold down bar

Load table

Thread Size	Critical Cross Section Area	Nominal Diameter	Linear Weight	Grade 835/1030		Grade 930/1080		Grade 1050/1200	
	(mm ²)	(mm)	(kg/m)	Yield Load (kN)	Ultimate Load (kN)	Yield Load (kN)	Ultimate Load (kN)	Yield Load (kN)	Ultimate Load (kN)
M33	694	31	5.92	579	715	645	750	729	833
M39	976	37	8.44	815	1,005	908	1,054	1,025	1,171
M45	1,307	43	11.40	1,091	1,346	1,216	1,412	1,372	1,568
M48	1,474	45	12.48	1,230	1,518	1,371	1,592	1,548	1,769
M52	1,758	49	14.80	1,468	1,811	1,635	1,899	1,846	2,110
M60	2,363	57	20.03	1,972	2,434	2,198	2,552	2,481	2,836
M68	3,056	65	26.04	2,551	3,148	2,842	3,300	3,209	3,667
M78	4,114	75	34.67	3,435	4,237	3,826	4,443	4,320	4,937
M88	5,329	85	44.54	4,450	5,489	4,956	5,755	5,595	6,395
M98	6,702	95	55.63	5,596	6,903	6,233	7,238	7,037	8,042
M103	7,447	100	61.64	6,218	7,670	6,926	8,043	7,819	8,936

Corrosion protection accessories

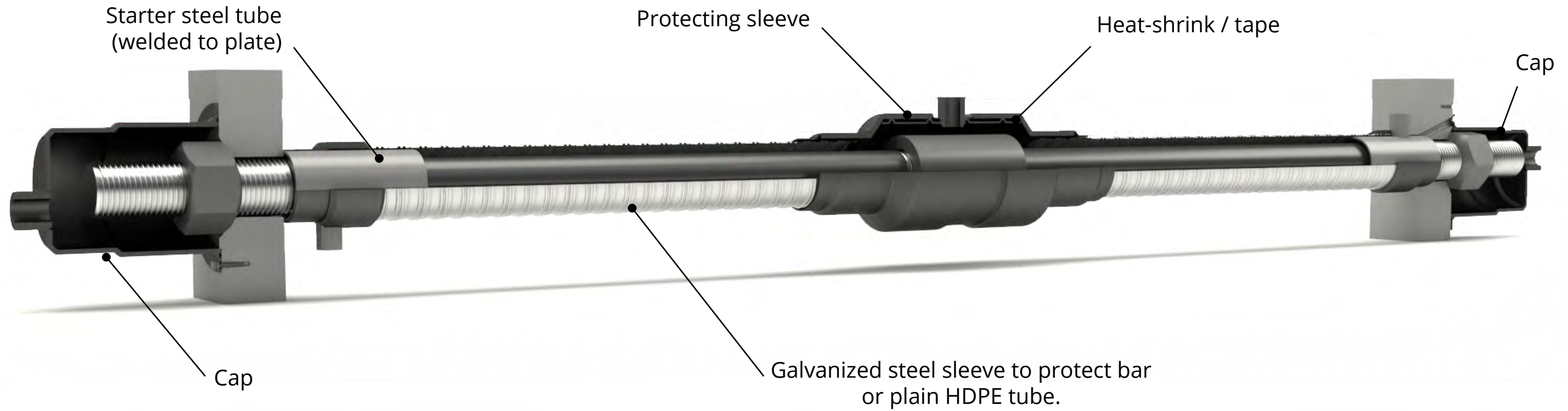

Nuts

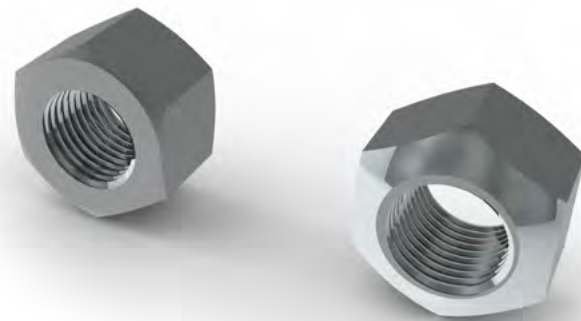

Bearing plates

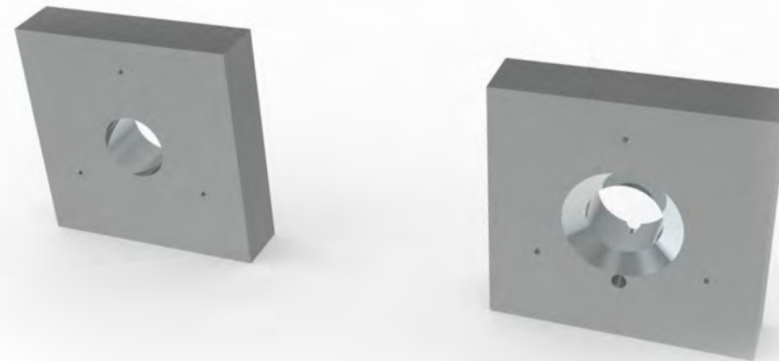

Coupler system

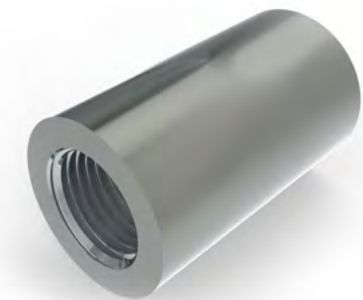

Fully threaded range



Design references

- AASHTO
- Eurocode 2

Product features

- Diameter range from 25 mm to 50 mm.
- Three steel grades available:
 - 830/1030.
 - 930/1080.
- Continuous hot rolled thread.

Product benefits

- Re-usable.
- Cuttable at site.
- Continuous thread makes connection possible at any point.
- Large pitch especially suitable for fast installation and temporary applications.
- Re-tensioning possible without any damage.
- Full range of accessories, including corrosion protection accessories, also supplied by Dextra.
- High grades 1080/1230 available.

Fully threaded systems load table

Nominal Diameter (mm)	Cross-section Area (mm ²)	Linear Weight (kg/m)	Grade 830/1030		Grade 930/1080	
			Yield Load (kN)	Ultimate Load (kN)	Yield Load (kN)	Ultimate Load (kN)
25	491	4.10	407	506	457	530
32	804	6.65	667	828	748	869
36	1,018	8.41	845	1,049	947	1,099
40	1,257	10.34	1,043	1,294	1,169	1,357
50	1,964	16.28	1,630	2,022	1,826	2,121

Corrosion protection accessories

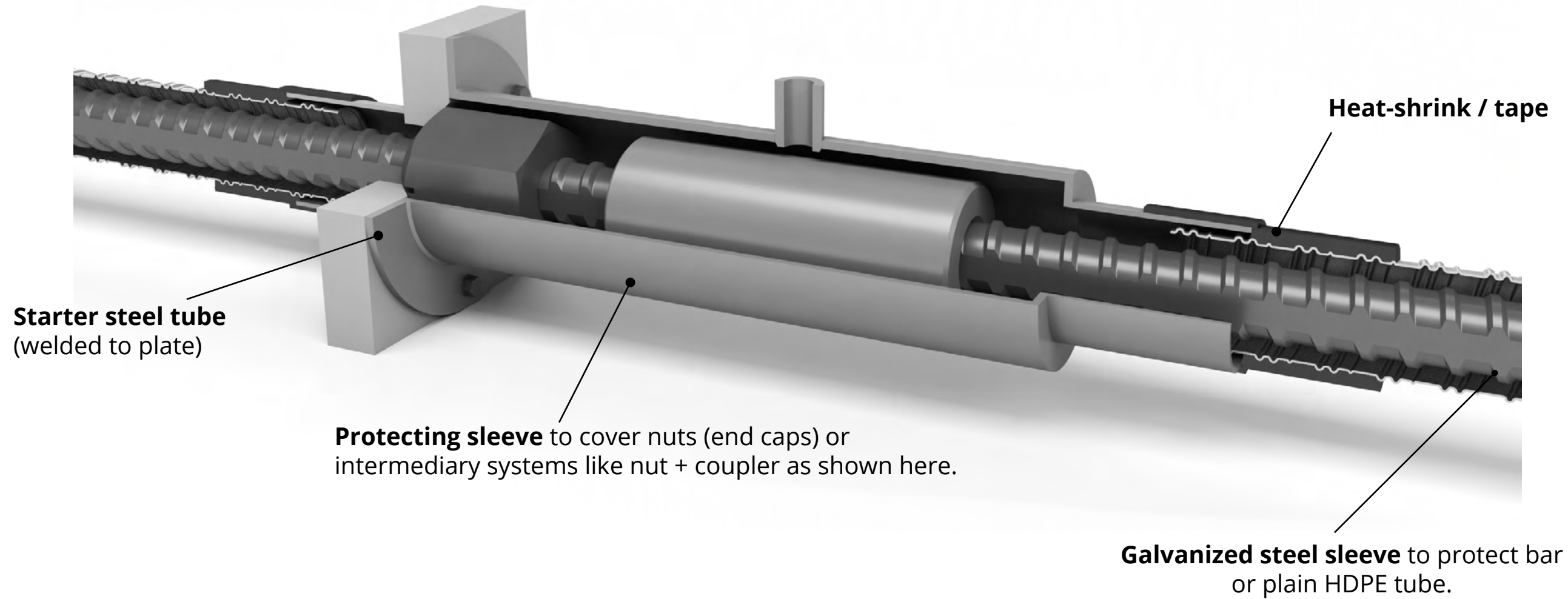

Nuts

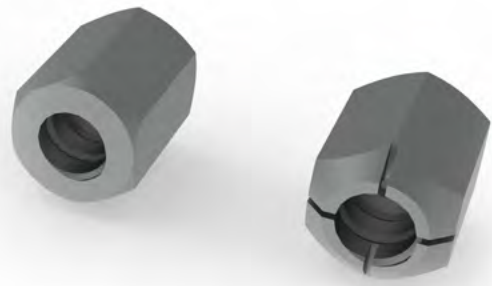

Bearing plates

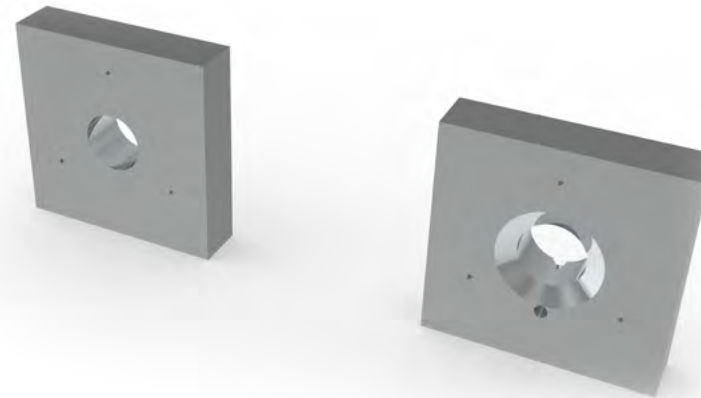

Coupler system





Resources



Brochure



Datasheet



Webpage

Project References



Chennai Metro, India

Elevated Stretch of NH-44 Banner, India

Binh Khanh Bridge, Vietnam

Bang Pa-In - Nakhon Ratchasima Motorway, Thailand

Nhat Tan Bridge, Vietnam

Causeway Across Kuwait Bay, Kuwait

Connect with us



www.dextragroup.com



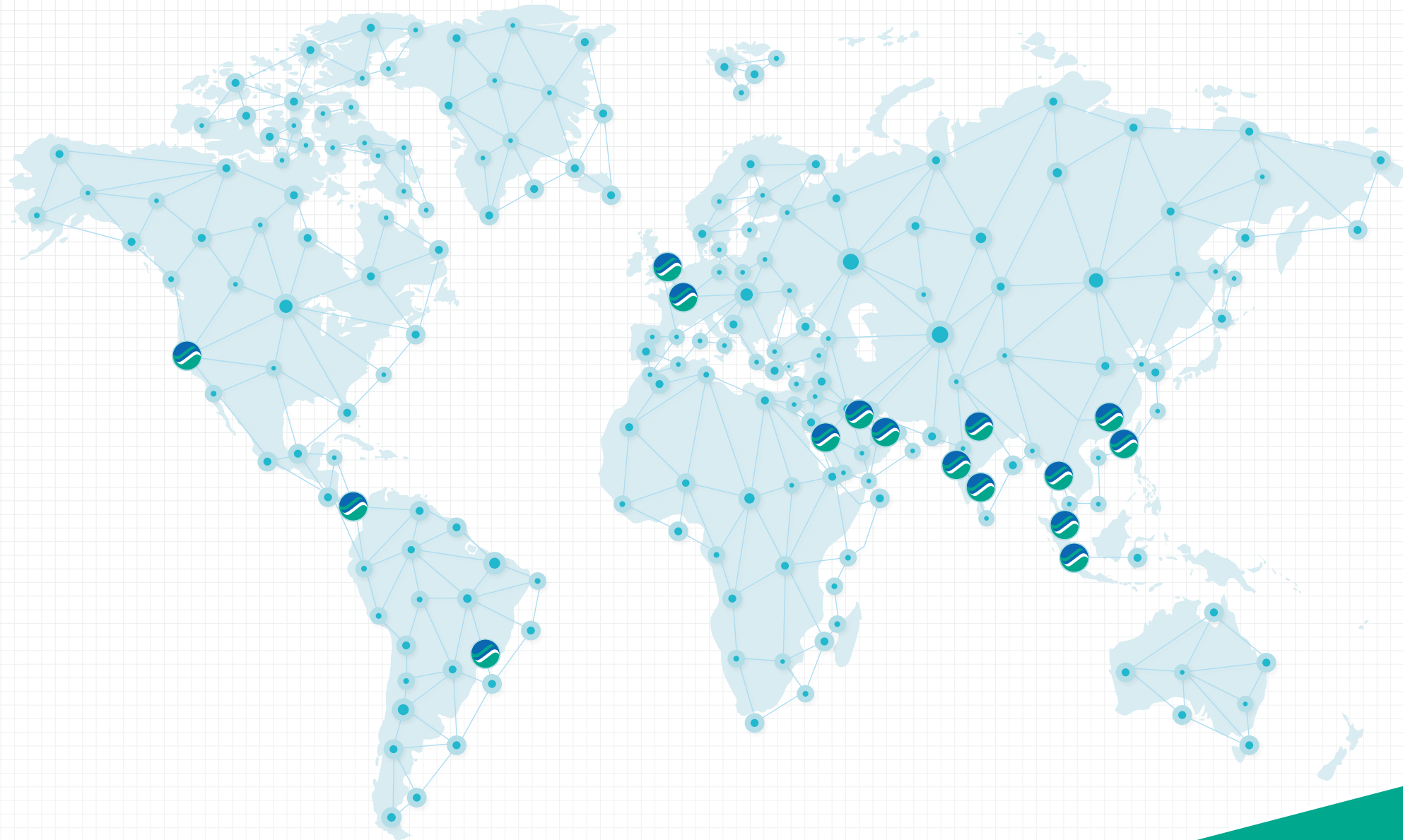

Commercial presence
in more than
55 countries



Dextra

www.dextragroup.com

Main offices (click on the address to see more information)

HEADQUARTERS THAILAND
Dextra Manufacturing Co., Ltd.
Tel: (66) 2 021 3800

CHINA
Dextra Building Products (Guangdong) Co., Ltd.
Tel: (86) 20 2261 9901

HONG KONG
Dextra Pacific Ltd.
Tel: (852) 2511 8236

EUROPE
Dextra Europe S.A.R.L.
Tel: (33) 1 45 53 70 82

MIDDLE EAST
Dextra Middle-East FZE
Tel: (971) 4886 5620

INDIA
Dextra India Pvt. Ltd.
Tel: (91) 22 2839 2694

NORTH AMERICA
Dextra America Inc.
Tel: (1) 206 742 6020

LATIN AMERICA
Dextra Latam
Tel: (507) 831 1442