

High Tensile Holding Down Bar

Restraint system for bridges, viaducts, foundation works, offshore platform and towers

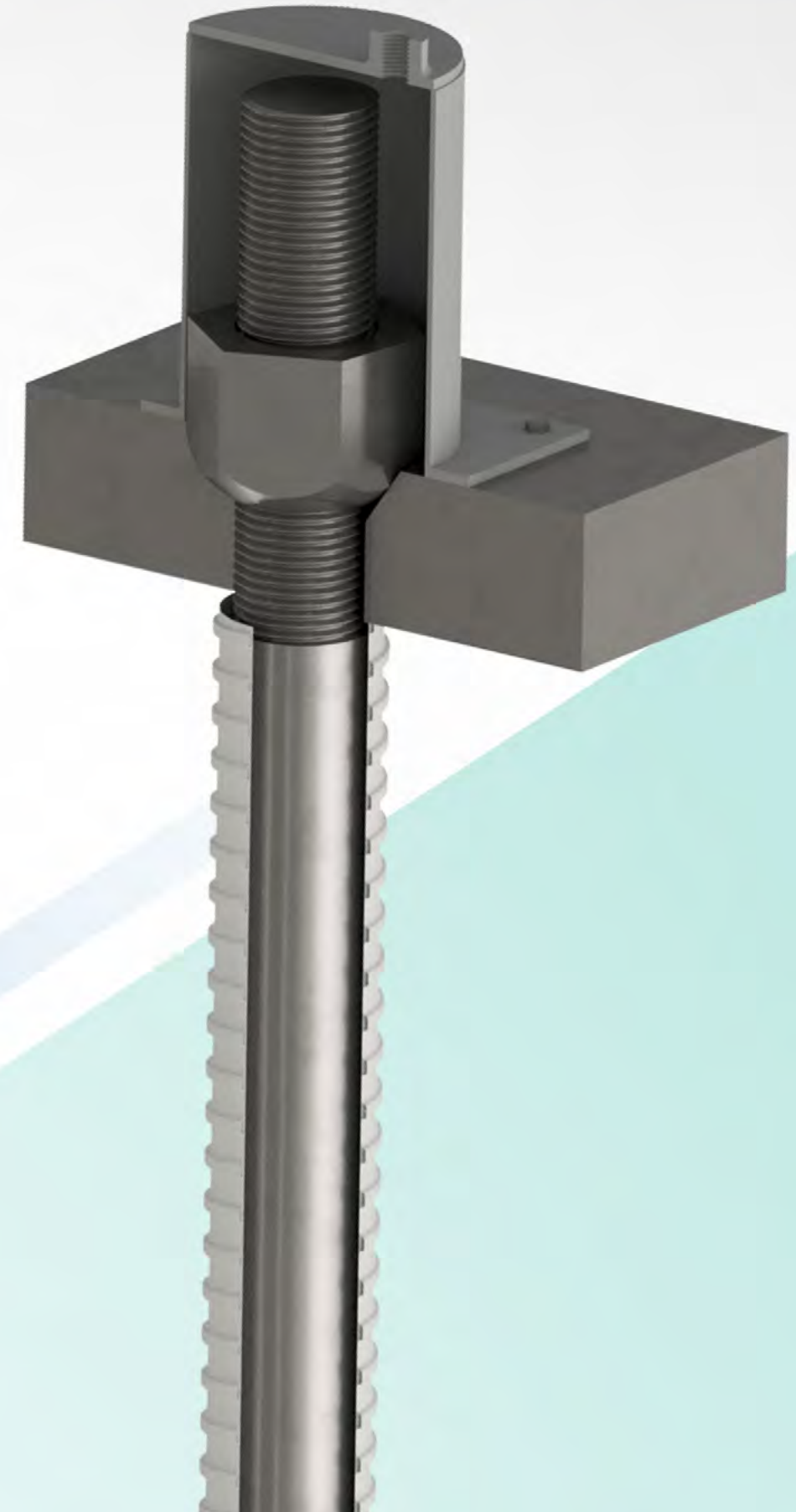

System description

High Tensile Holding Down Bars are a special application for smooth Post Tensioning bar systems for the connection between steel and concrete elements or concrete to concrete elements.

The core accessories of the system are:

- High tensile bar with threaded ends
- Hex nuts
- Swivel plates
- Swivel nuts

Please contact your local Dextra office for technical assistance.

System accessories

As a permanent external and unbonded system, corrosion protection of the bar, nut and accessories are required.

For corrosion protection, a protection cap can be supplied which bolts onto the end bearing plate over the bar end, nut and washer. This can then be filled with grease on site after installation and stressing.

The duct, through which the bar passes, is not supplied by Dextra, but can be sourced locally as per the project requirements.

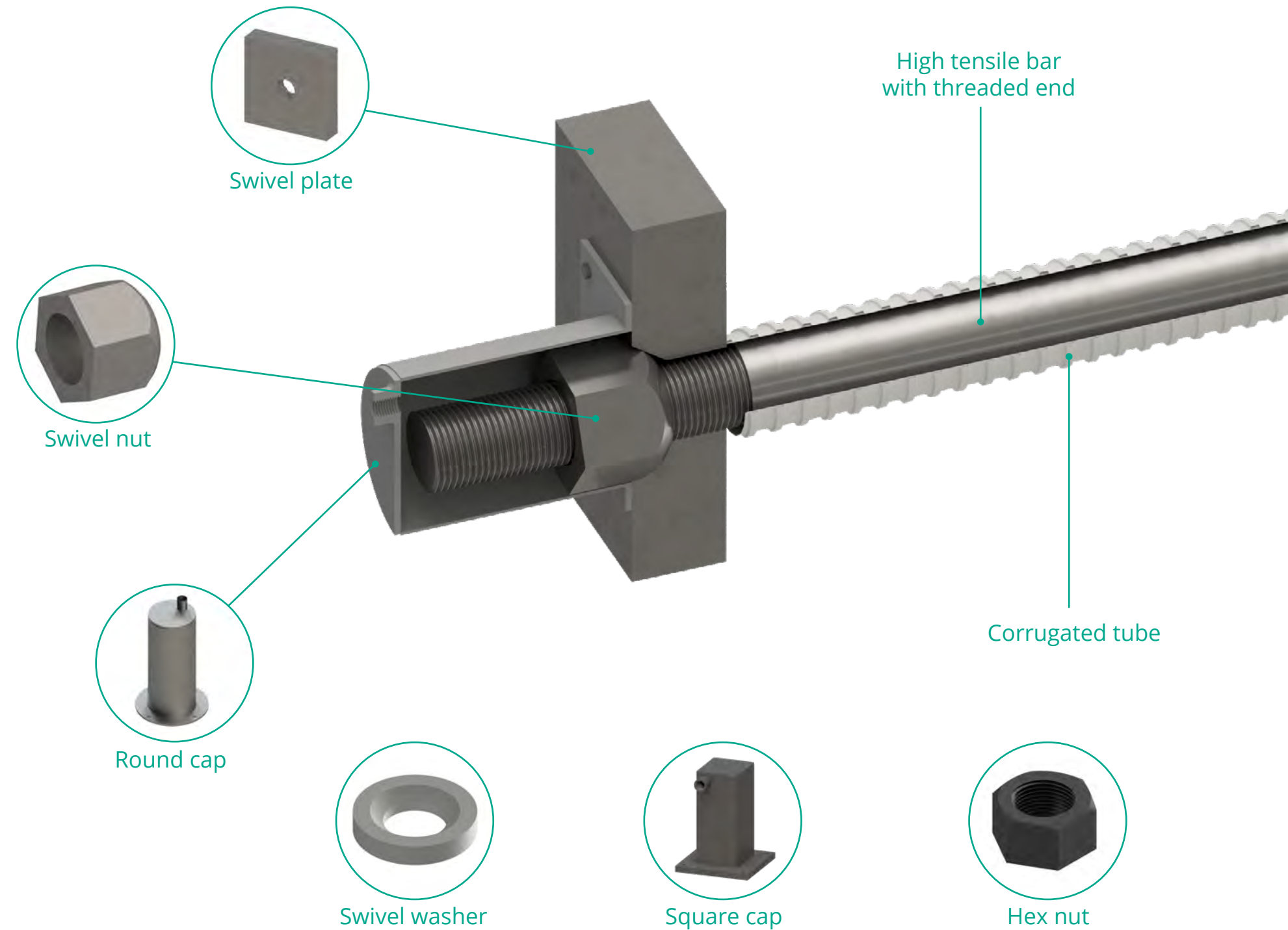

Product features

- Diameters range from 31mm (thread M33) to 100mm (thread M103).
- 3 steel grades are available: 835/1030, 930/1080 and 1050/1200.
- Rolled threads (obtained with cold plastic deformation of the metal between two dies) optimized for fatigue performance.
- ISO metric thread as per ISO 965-1.

Benefits

- High ductility, fatigue resistance, impact resistance.
- Full traceability and individual bar labelling.
- Ready-to-install conditions.
- Sea-worthy packing.
- Project engineering support by Dextra dedicated Bar Systems Engineering team.

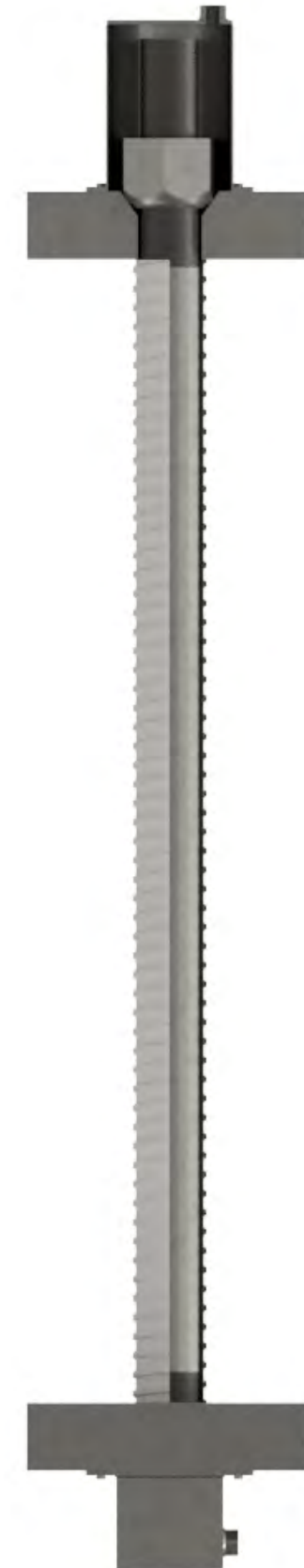

Applications

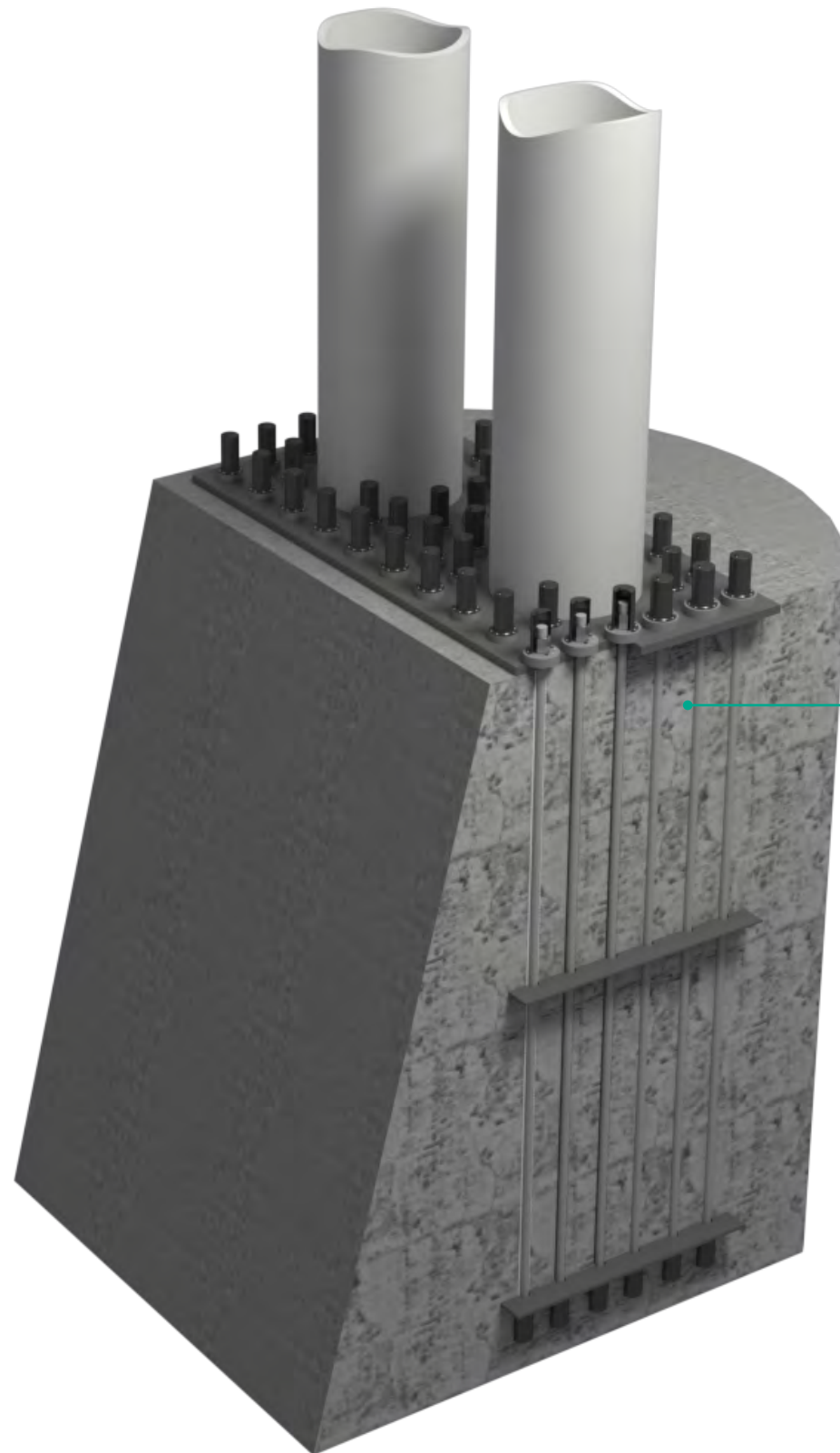

Holding Down Bars are a type of anchorage to connect steel to concrete, or concrete to concrete elements. They are typically used vertically for the holding down of structures or structural elements to concrete foundations.

Typical applications include the holding down bars for wind turbines, for the connection of steel pylons to concrete foundations, and for the connection of precast concrete elements.

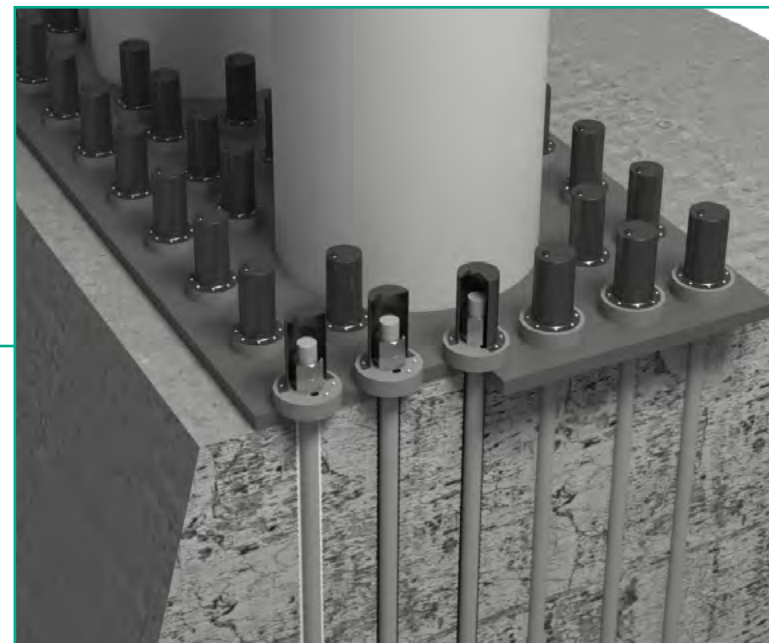

Each bar tendon is typically terminated via a nut bearing onto steelwork or a steel plate.

In order to eliminate bar stretch and hence movement under externally applied loads, the bar is usually tensioned using a hydraulic jack.

The jack is attached to the bar and a load is applied before the nut is then wound down into contact with the steel plate and the jack released.



Load table: Smooth bars

Bar thread size	Critical cross section area	Nominal diameter	Linear weight	Grade 835/1030		Grade 930/1080		Grade 1050/1200	
	(mm ²)	(mm)	(kg/m)	Yield load (kN)	Ultimate load (kN)	Yield load (kN)	Ultimate load (kN)	Yield load (kN)	Ultimate load (kN)
M33	694	31	5.9	579	714	645	749	728	832
M39	976	37	8.4	815	1,005	907	1,054	1,025	1,171
M42	1,121	40	9.9	936	1,155	1,042	1,211	1,177	1,345
M45	1,306	43	11.4	1,091	1,345	1,215	1,410	1,371	1,567
M48	1,473	45	12.5	1,230	1,517	1,370	1,591	1,547	1,768
M52	1,758	49	14.8	1,468	1,811	1,635	1,898	1,846	2,109
M60	2,362	57	20.0	1,972	2,433	2,197	2,551	2,480	2,834
M68	3,055	65	26.0	2,551	3,147	2,841	3,300	3,208	3,666
M78	4,114	75	34.7	3,435	4,237	3,826	4,443	4,319	4,936
M88	5,329	85	44.5	4,450	5,489	4,956	5,755	5,595	6,395
M98	6,701	95	55.6	5,596	6,902	6,232	7,237	7,036	8,042
M103	7,446	100	61.7	6,218	7,670	6,925	8,042	7,819	8,936

Load table: Fully-threaded bars

Bar nominal diameter	Max diameter	Pitch	Cross-section area	Linear weight	Grade 830/1030		Grade 930/1080	
					Yield load	Ultimate load	Yield load	Ultimate load
(mm)	(mm)	(mm)	(mm ²)	(kg/m)	(kN)	(kN)	(kN)	(kN)
25	28	12	491	3.9	407	506	457	530
32	36	16	804	6.3	668	828	748	869
36	41	18	1,018	8.0	845	1,048	947	1,099
40	45	20	1,257	9.9	1,043	1,294	1,169	1,357
50	56	24	1,963	15.4	1,630	2,022	1,826	2,121

Reference projects



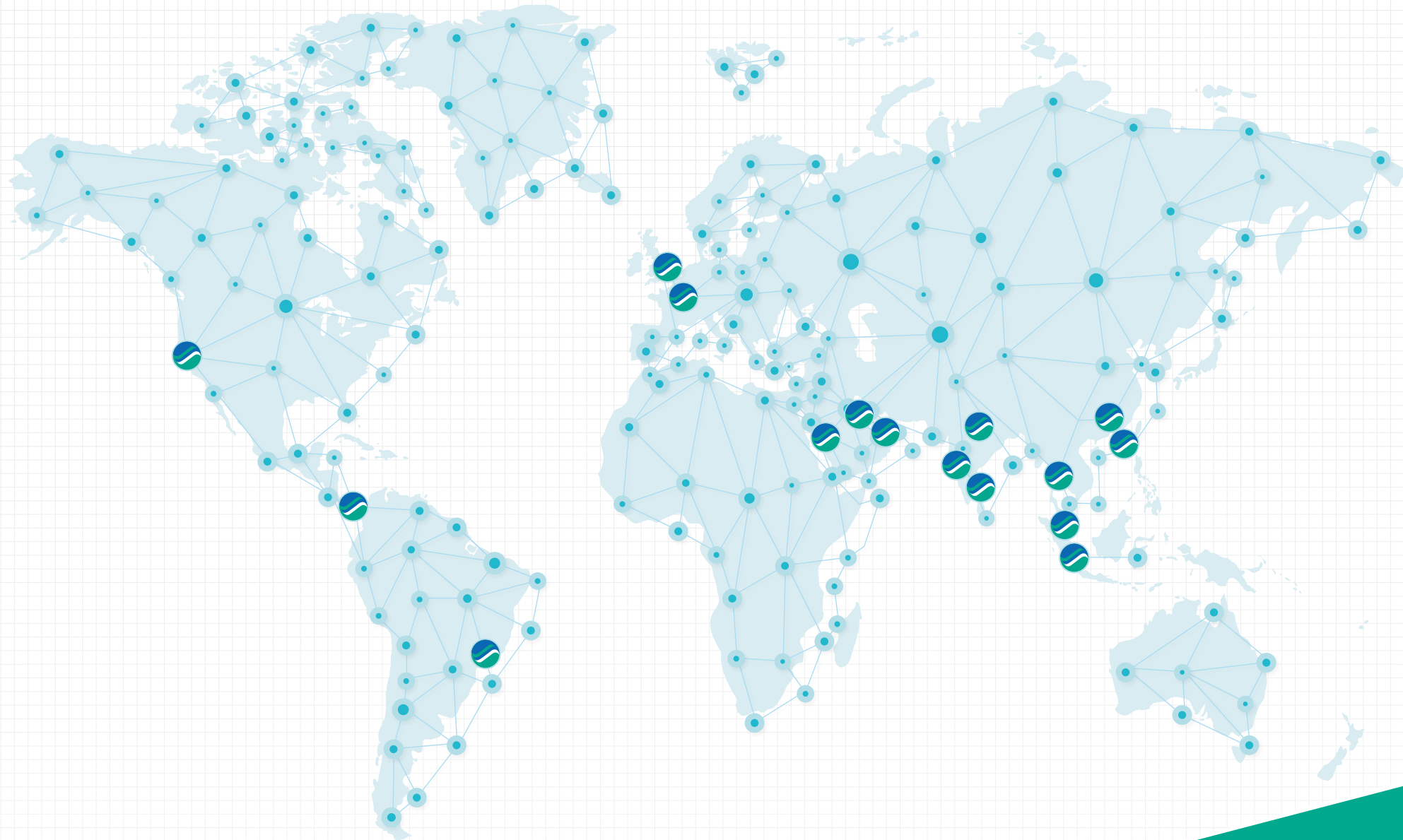

Commercial presence
in more than
55 countries



Main offices (click on the address to see more information)

HEADQUARTERS THAILAND
Dextra Manufacturing Co., Ltd.
Tel: (66) 2 021 3800

CHINA
Dextra Building Products (Guangdong) Co., Ltd.
Tel: (86) 20 2261 9901

HONG KONG
Dextra Pacific Ltd.
Tel: (852) 2511 8236

EUROPE
Dextra Europe S.A.R.L.
Tel: (33) 1 45 53 70 82

MIDDLE EAST
Dextra Middle-East FZE
Tel: (971) 4886 5620

INDIA
Dextra India Pvt. Ltd.
Tel: (91) 22 2839 2694

NORTH AMERICA
Dextra America Inc.
Tel: (1) 206 742 6020

LATIN AMERICA
Dextra Latam
Tel: (507) 6454 8100