

CARES Technical Approval Report TA1-B 5011

Issue 6



Dextra



DEXTRA Bartec/Fortec Parallel Thread Couplers

Assessment of the
DEXTRA Bartec/Fortec
Parallel Threaded Coupler
Product and Quality
System for Production

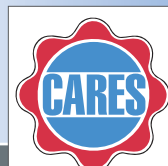

**TECHNICAL
APPROVAL**
5011



002

Product

DEXTRA Bartec/Fortec
Parallel Threaded
mechanical couplers
for reinforcing steel

Product approval held by:

DEXTRA Manufacturing Co. Ltd,
5th Floor Lumpini II Building
247 Sarasin Road
Lumpini Pathumwan
Bangkok 10330 Thailand

Tel: +66 2651 9027
Fax: +66 2651 8000

1 Product Summary

DEXTRA Bartec/Fortec parallel threaded mechanical couplers are for the mechanical connection of deformed high yield carbon steel bars for the reinforcement of concrete complying with the requirements of BS4449 Grade B500B.

1.1 Scope of Application

DEXTRA Bartec/Fortec parallel threaded standard and positional mechanical couplers, in the size range 12mm - 40mm, have been evaluated for use as follows:

Static tension applications in reinforced concrete structures designed for EC2 and BS8110: Part 1: in accordance with CARES Appendix TA1-B.

1.2 Design Considerations

BS 8110 Clause 3.12.8.9 *Laps and Joints* states "Connections transferring stress may be lapped, welded or joined with mechanical devices. They should be placed, if possible, away from points of high stress and should preferably be staggered". However, BS 8110 Clause 3.12.8.16.2 *Bars in tension* states "The only acceptable form of full-strength butt joint for a bar in tension comprises a mechanical coupler" satisfying specified slip and tensile strength criteria.



Eurocode 2, Clause 8.7 Laps and mechanical couplers 8.7.1 General (1)P "Forces are transmitted from one bar to another by:

- lapping of bars, with or without bends or hooks;
- welding;
- mechanical devices assuring load transfer in tension-compression or in compression only."

Clause 8.8 Additional rules for large diameter bars goes on to state that "Splitting forces are higher and dowel action is greater with the use of large diameter bars. Such bars should be anchored with mechanical devices."

The specified cover for fire resistance and durability should be provided to the coupler sleeve. All couplers have been designed with controlled mechanical properties to be compatible with reinforcing bars complying with BS4449 Grade B500B.

1.3 Conclusion

It is the opinion of UK CARES that DEXTRA Bartec/Fortec parallel threaded standard and positional mechanical couplers are satisfactory for use within the limits stated in paragraph 1.1 when applied and used in accordance with the manufacturer's instructions and the requirements of this certificate.

Lee Brankley

L. Brankley
Chief Executive Officer

July 2018



2 Technical Specification

2.1 General

DEXTRA Bartec/Fortec parallel threaded mechanical couplers are for joining deformed grade B500B steel reinforcing bars complying with BS4449.

2.2 Bartec/Fortec Standard Coupler

The Bartec/Fortec standard coupler is designed for use where one of the bars to be spliced can be rotated. It comprises a steel sleeve with an internal parallel thread, the rebar is upset and then a matching external parallel thread is applied.

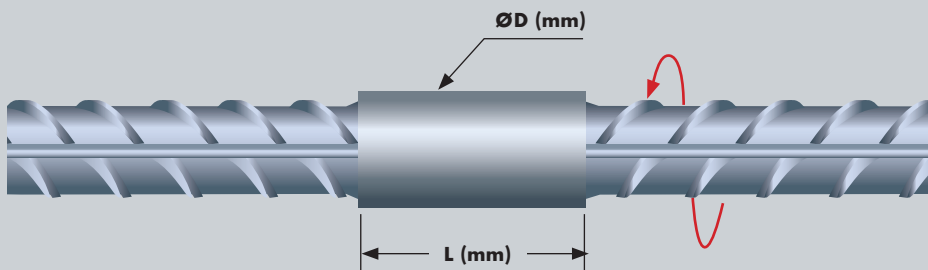

Size mm	Art No	D (mm)	L (mm)	Thread (mm)	Weight (kg)	Plastic protection colour	Reinforcement Grade
12	FPBS1214003	20	28	M14 x 2.0	0.04	Yellow	B500B
16	FPBS1620003	28	40	M20 x 2.5	0.07	Lavender	B500B
20	FPBS2024003	32	48	M24 x 3.0	0.16	Orange	B500B
25	FPBS2530003	40	60	M30 x 3.5	0.31	Clear	B500B
32	FPBS3236003	50	72	M36 x 4.0	0.63	Light Blue	B500B
40	FPBS4045003	62	90	M45 x 4.5	1.20	Blue	B500B

Table 1 Bartec "BS" coupler

Size mm	Art No	D (mm)	L (mm)	Thread (mm)	Weight (kg)	Plastic protection colour	Reinforcement Grade
12	FPBF1214201	20	28	M14 x 2.0	0.04	Yellow	B500B
16	FPBF1620255	26	44	M20 x 2.5	0.14	Lavender	B500B
20	FPBF2024305	31	52	M24 x 3.0	0.23	Orange	B500B
25	FPBF2530355	39	66	M30 x 3.5	0.42	Clear	B500B
32	FPBF3236405	48	78	M36 x 4.0	0.73	Light Blue	B500B
40	FPBF4045455	60	97	M45 x 4.5	1.15	Blue	B500B

Table 2 Bartec/Fortec coupler

2.3 Bartec/Fortec Positional Coupler

The Bartec/Fortec position coupler is designed for use when both bars would be a burden to rotate, for example because of their size or length, the Bartec/Fortec splice system simply extends the thread onto the ribs of the bar, thereby enabling the coupler to be fully screwed onto it. It is then unscrewed from one bar and back onto the second bar to accomplish the connection.

The Bartec/Fortec couplers for position type are the same as for standard type which can be referred to in table 1 (Bartec "BS") and table 2 (Bartec/Fortec).

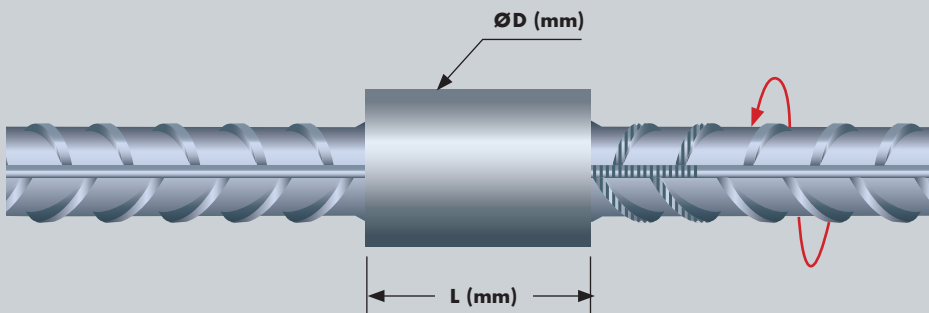

3 Product Performance and Characteristics

Full tests have been carried out to demonstrate compliance with performance requirements defined in CARES Appendix TA1-B including the performance requirements of EC2 and BS8110 when used with reinforcing bars to BS4449 Grade B500B.

CARES APPENDIX TA1-B

- Permanent deformation is less than 0.10mm at 325 MPa for B500B in tension.



4 Installation

The bars to be spliced are cut straight and cold-upset using the DEXTRA forging machine, and then finally threaded.

The machines must be operated by suitably trained staff in accordance with DEXTRA operating instructions.

The parts are screwed together and tightened using a suitable wrench.



Dextra forging machine

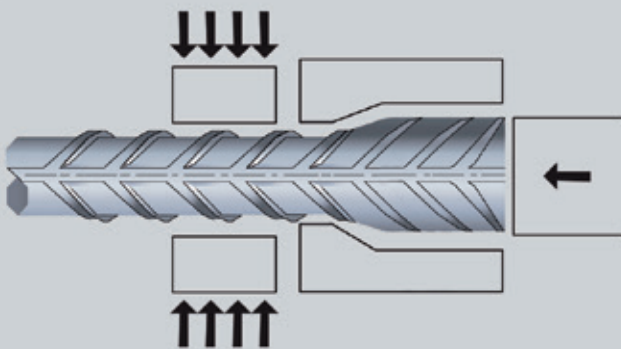

Cold upsetting



Threaded bar

5 Safety Considerations

Couplers are supplied in wooden containers and have a maximum weight of 2000 kg and must be handled with appropriate lifting equipment. It is advisable to wear suitable protective gloves during handling the containers, couplers and reinforcement; during the cutting forging and threading process and during coupler installation.

6 Product Testing and Evaluation

DEXTRA Bartec/Fortec parallel threaded couplers have been tested to satisfy the requirements of EC2 and BS8110 when used with reinforcing bars to BS4449 Grade B500B.

The testing comprised the following elements:

EC2 and BS8110

- Tensile Strength
- Permanent Deformation

The products are subject to a programme of periodic testing to ensure that they remain within the performance limits of this technical approval.

7 Quality Assurance

DEXTRA Bartec/Fortec couplers are produced under an ISO9001 quality management system certified by CARES. The quality assurance scheme monitors the production of the couplers and ensures that materials and geometry remain within the limits of this technical approval.



8 Building Regulations

8.1 The Building Regulations (England and Wales)

Structure, Approved Document A

DEXTRA Bartec/Fortec standard and positional couplers, when used in EC2 based designs using the data contained within this technical approval, satisfy the relevant requirements of The Building Regulations (England and Wales), Approved Document A.

Materials and Workmanship, Approved Document

This technical approval gives assurance that the DEXTRA Bartec/Fortec standard and positional couplers comply with the material requirements of EC2.

8.2 The Building Regulations (Northern Ireland)

Materials and Workmanship

This technical approval gives assurance that DEXTRA Bartec/Fortec standard and positional couplers comply with the material requirements of EC2 by virtue of regulation 23, *Deemed to satisfy provisions regarding the fitness of materials and workmanship*.

8.3 The Building Standards (Scotland)

Fitness of Materials

This technical approval gives assurance that DEXTRA Bartec/Fortec standard and positional couplers comply with the material requirements of EC2 by virtue of *Clause 0.8*.

Structure

DEXTRA Bartec/Fortec standard and positional couplers, when used in EC2 based designs using the data contained within this technical approval, satisfy the requirements of *The Building Standards (Scotland) clause 1*.

9 References

- BS 4449:2005 Specification for carbon steel bars for the reinforcement of concrete.
- BS 8110:Part 1:1997 (Amended 2007) Structural use of concrete, Code of practice for design and construction.
- BS EN 1992-1-1:2004 Eurocode 2 Design of concrete structures - General rules for buildings
- BS EN ISO 9001: Quality Systems. Model for quality assurance in production, installation and servicing.
- TA1-B Quality and Operations Schedule for the Technical Approval of Couplers for Reinforcing Steel For BS8110 and EN1992-1-1 Applications for Static Loading in Tension or Tension and Compression.



10 Conditions

1. The quality of the materials and method of manufacture have been examined by CARES and found to be satisfactory. This technical approval will remain valid provided that:
 - a. The product design and specification is unchanged.
 - b. The materials, method of manufacture and location are unchanged.
 - c. The manufacturer complies with CARES regulations for technical approvals.
 - d. The manufacturer holds a valid CARES Certificate of Product Assessment.
 - e. The product is installed and used as described in this report.
2. CARES make no representation as to the presence or absence of patent rights subsisting in the product and/or the legal right of DEXTRA to market the product.
3. Any references to standards, codes or legislation are those which are in force at the date of this certificate.
4. Any recommendations relating to the safe use of this product are the minimum standards required when the product is used. These requirements do not purport to satisfy the requirements of the Health and Safety at Work act 1974 or any other relevant safety legislation.
5. CARES does not accept any responsibility for any loss or injury arising as a direct or indirect result of the use of this product.
6. This Technical Approval Report should be read in conjunction with CARES Certificate of Product Assessment No 5011. Confirmation that this technical approval is current can be obtained from UK CARES.

Bartec/Fortec Coupler Applications



Bartec/Fortec couplers in diaphragm wall



Bartec/Fortec couplers in pile cages



Bartec/Fortec couplers in columns

Electronic Copy www.ukcares.com





Electronic Copy www.ukcares.com



UK CARES

Pembroke House
21 Pembroke Road
Sevenoaks
Kent TN13 1XR

Phone: +44(0)1732 450000
E-mail: general@ukcares.com
URL: www.ukcares.com

**Independent Product Assessments
for the Construction Industry**

Copyright UK CARES ©