

FORTEC

The Ultimate Splicing System



Dextra

www.dextragroup.com

Product features

Fortec® is a parallel threaded mechanical splicing system designed for the connection of concrete reinforcing bars from Ø12 to 50 mm (ASTM #4 to #18).

Fortec® couplers are designed and manufactured in compliance with Eurocode 2, BS 8110, DIN 1045, ACI 318, IBC, AASHTO, ASME Sec III Div 2.

Benefits

- One standard coupler for all splicing requirements (Standard / Position).
- Easy installation, no torque wrench required.
- No reduction of the bar cross section area.
- Allows full ductile elongation of bars.
- Type 2 coupler suitable for seismic areas.
- Tested under reverse cyclic conditions.
- Solves bar congestion problems.

Site equipment



The 3 machines necessary to Fortec® system rebar preparation are engineered by Dextra and delivered in a single container.

Rebar preparation: A 3-Step Process

STEP 01 Cutting

The end of the reinforcing bar is sawn square.



STEP 02 Cold forging

The sawn end of the reinforcing bar is then enlarged by a patented cold forging process. The core diameter of the bar is increased to a pre-determined size.



STEP 03 Threading

Finally, the enlarged end of the rebar is threaded to the required length.

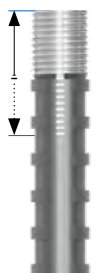

Splicing methods

Standard splice

Easy connection by bar rotation until full thread engagement.

Thanks to the parallel thread:

- No risk of thread mis-match.
- No risk of cross-threading.



Position splice

Even when both bars cannot be turned, the Fortec® system uses a standard coupler.

STEP 1:

The coupler is fully engaged onto the extended thread of the connecting bar.

STEP 2:

The assembly is simply completed by butting the bars end to end and screwing back the coupler onto the first bar until full engagement (step 2).



Position Type C is similar to Type B, with the addition of a lock nut to maintain the second bar in position.

Applications

Caging splice

To connect cages that have not been pre-fabricated together or sets of bars that can not be brought butt to butt, Fortec® Caging splice is your solution.

Both bars are threaded with a standard Fortec® thread, then the free rotating elements of the Caging Splice will restore thread continuity and make the connection.

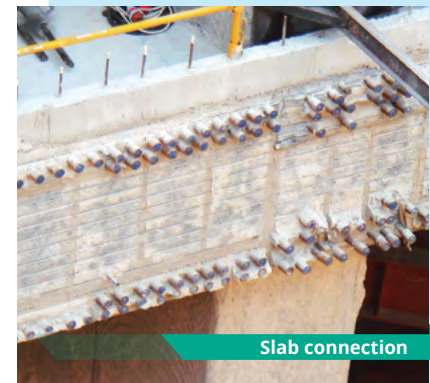
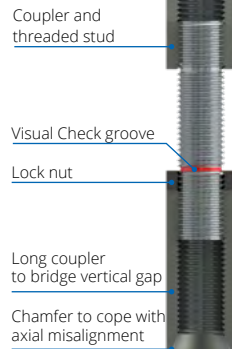

Slab connection

Transition splice

When there is a need to splice bars of different sizes, it is allowable in most cases to reduce the size of the larger bar and to use a standard coupler.

However, the Fortec® system also offers special transition couplers that conveniently avoid the difficult task of planning in advance the need of transitions.



Columns

Headed bars

Also called "End Anchors" they are convenient alternative to hooked bars. Providing end anchorages in congested areas. Fortec® standard anchorage heads are circular and have a net bearing area of 4 times or 9 times the cross-section of the bar.

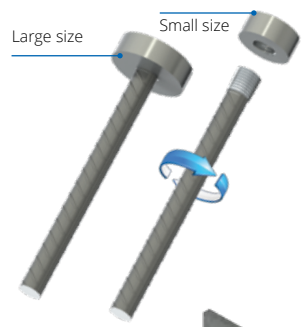

Prefabricated Cages

Weldable couplers

For composite construction where concrete reinforcement bars must be welded to structural steel, use Fortec® weldable couplers. They are specially made from low carbon steel, and have a large chamfer for bevel welding.



Quality Assurance



Generic specification

- › No reduction of the nominal cross section area of the parent bars.
- › No reduction of the ductility of the reinforcing bar.
- › Couplers are individually marked to allow full traceability of the material.
- › Parallel-thread system.

Note : The information in this catalogue is considered up to date at the time of publication. We reserve the right to make technical and design changes at any time. Dextra shall not accept liability for the accuracy of the information in this publication or for any printing errors.

Approvals & Certifications



Design tools

Available on www.dextragroup.com





International Commerce Centre (ICC), Hong Kong

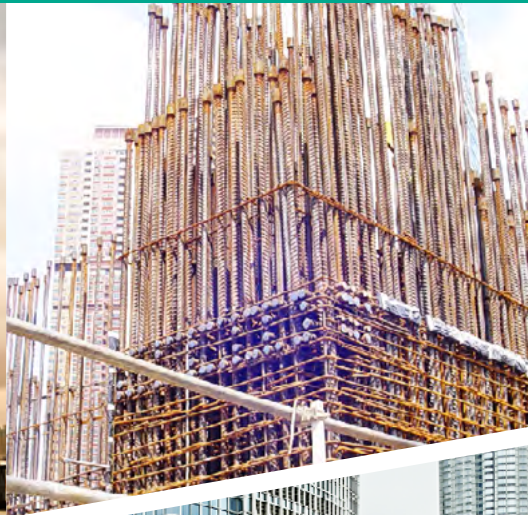

Two IFC (International Finance Centre), Hong Kong



Hong Kong - Zhuhai - Macau Link, Hong Kong



Commercial presence
in more than
55 countries



Dextra

**HEADQUARTERS
THAILAND**

Dextra Manufacturing Co.,Ltd.
Tel: (66) 2 021 3800

CHINA

Dextra Building Products (Guangdong) Co.,Ltd.
Tel: (86) 20 2261 9901

HONG KONG

Dextra Pacific Ltd.
Tel: (852) 2511 8236

EUROPE

Dextra Europe SARL
Tel: (33) 1 45 53 70 82

MIDDLE EAST

Dextra Middle East FZE
Tel: (971) 4886 5620

INDIA

Dextra India Pvt.,Ltd.
Tel: (91) 22 2839 2694

NORTH AMERICA

Dextra America Inc.
Tel: (1) 206 742 6020

LATIN AMERICA

Dextra Latam
Tel: (507) 831 1422

BRAZIL

Dextra do Brasil
Tel: (55) 119 7577 8112