

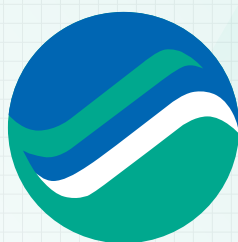

## PRODUCT DATASHEET

*Griptec® GPC-GPD RANGE PDS-018-Rev.00-en October 2019*

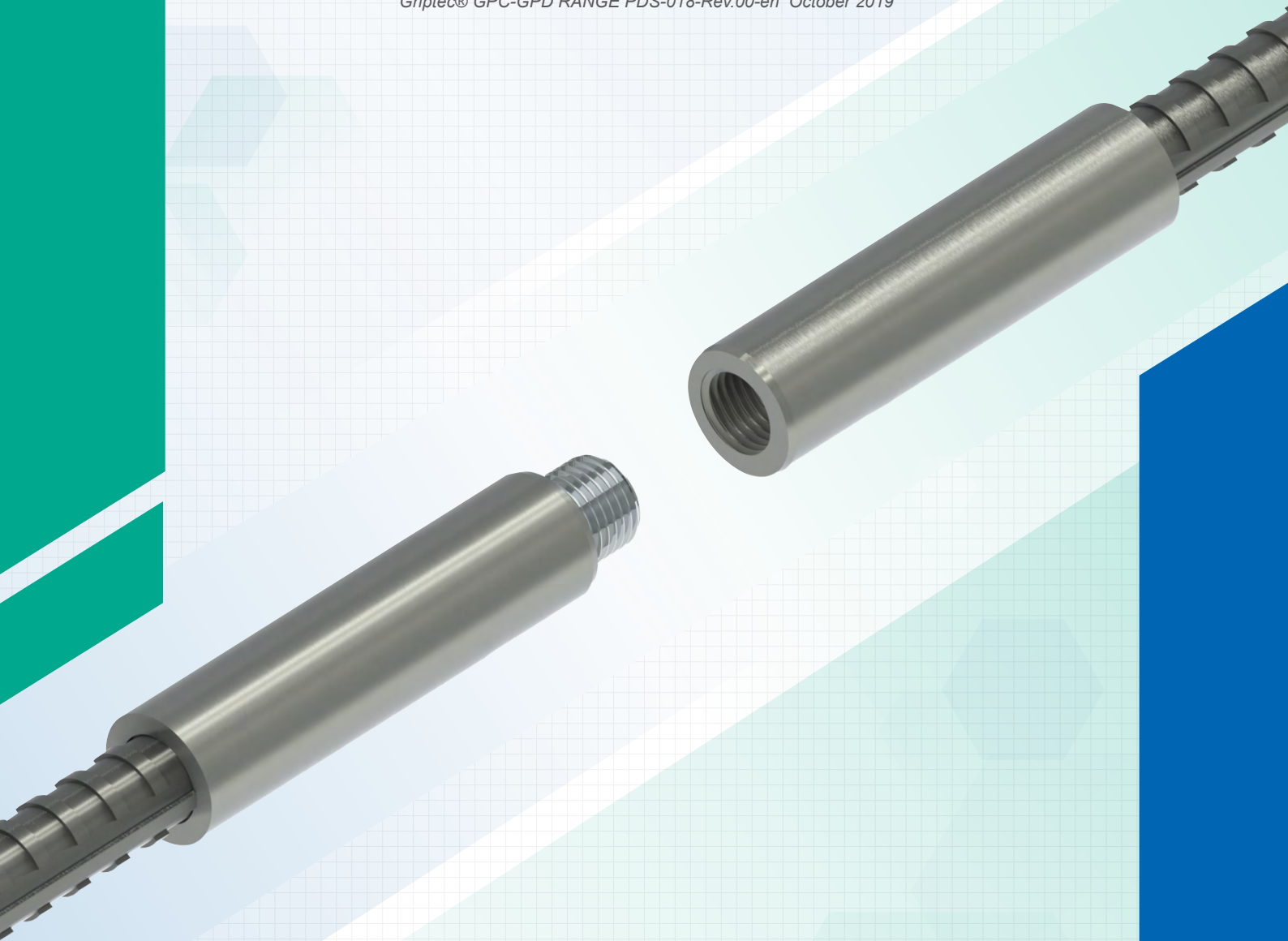

**Dextra**

[www.dextragroup.com](http://www.dextragroup.com)

# CONTENT

03

04

05

06

07

08

10

11

12

13

14

15

16

17

# Product Description

The Griptec® system is the most accomplished reinforcing bar end preparation process to-date:

- Effortless: factory-made threaded sleeves are fixed onto the bar ends by a fully-automatic extrusion machine.
- Safe: the CE-compliant, fully-protected extrusion machine doesn't allow access to mobile parts when it is in use.
- Mistake-free: the Griptec machine auto-adjusts its processing parameters when switching from one bar size to another.
- Controlled: the Griptec machine automatically performs a tensile pull on each and every connection that is manufactured.
- Fast: each bar end preparation takes only about 30 seconds.
- Clean: no dirty oil coolant or machining chips.
- Handy: parallel threads do not require a torque wrench for site assembly.

The Griptec® system guarantees an ultimate tensile strength greater than bars, up to 700 MPa.

**No room for error: Systematic proof-testing of each and every bar end produced !**

Load testing of the bar end is an integral part of the Griptec® bar end preparation process.



This is a non-destructive test: The tensile load is less than the nominal yield strength of the bar, typically at 90% of Re (70% for dia 40 up), by which 100% of the bar ends are tested at a load higher than their design working load.

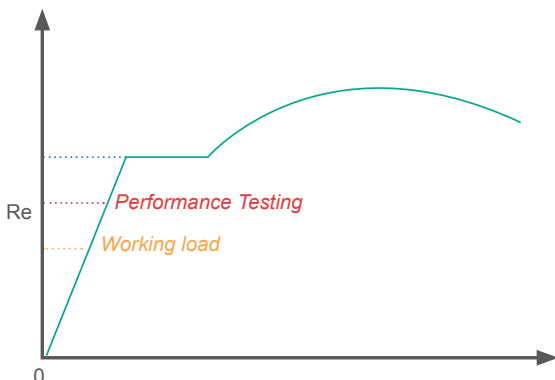

The Griptec® system doesn't apply to smooth bars.

Bar end preparation must be done exclusively with machines provided by Dextra. Consult us for technical details of our range of machinery (please specify the minimum and maximum bar diameters that you need to process).

Griptec® couplers and anchor plates can be epoxy-coated by any means. Their internal threads must be protected before processing.

The surface condition of Griptec® couplers and anchor plates conforms to ACI 318 (2008) § 7.4.2, ACI 349 (2006) § 7.4, ASME Section III Division 2 § CC-4360 and B.S. 5400 Part 7 § 4.5. Weldable couplers furthermore conform to ANSI/AWS D1.1-88 § 3.2.1.



## CAD & BIM

CAD & BIM tools to support design engineers in the drawing and modeling of structures are available in the download section of [www.dextragroup.com](http://www.dextragroup.com)

For designer tools support, contact us at: [cadbim@dextragroup.com](mailto:cadbim@dextragroup.com)



## About Griptec®

The Griptec® mechanical splice system consists of threaded sleeves that are fixed onto the reinforcing bar ends. A combination of male and female sleeves creates the connection. The GRIPTEC® system uses isometric parallel threads, so its mechanical performance in compression equals that in tension.

Female sleeves are generally used on first-phase bars, in order to ease the closing of the formworks. Male sleeves are generally used on continuation bars. However pocket formers are available when male sleeves are used in first place bars.

For all types of connections, the preparation of the reinforcing bar is the same : either a female or a male sleeve is swaged onto the end of the bar by deforming the material of the sleeve so that it interlocks intimately with the ribs of the bar.

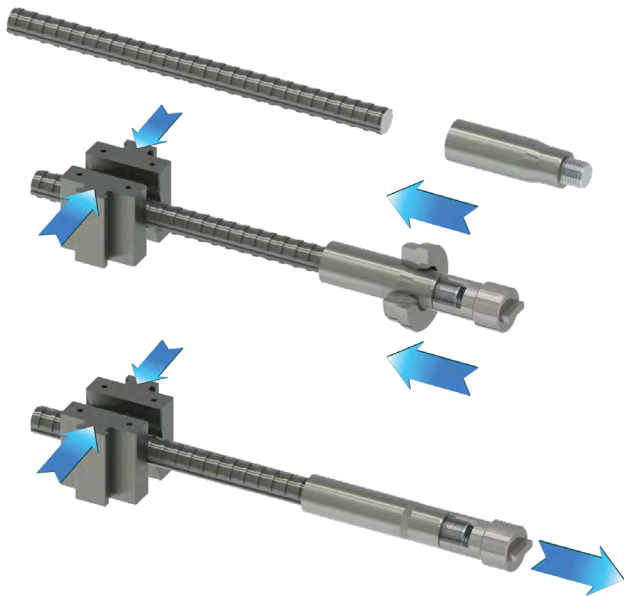

Standard splices use nothing else than a female sleeve and a male sleeve.

Other types of connections use additional elements, which combine with the male and female sleeves in order to achieve the function sought. The product codes of the male and female sleeves are given at the Standard Splices section. In the other sections, only the product codes of the additional elements are given ; the sleeves must be purchased as per the product codes given in the Standard Splices section.

## Standard Splices

Standard Griptec® splices are accomplished by use of a standard female coupler and a standard male coupler of the matching size.

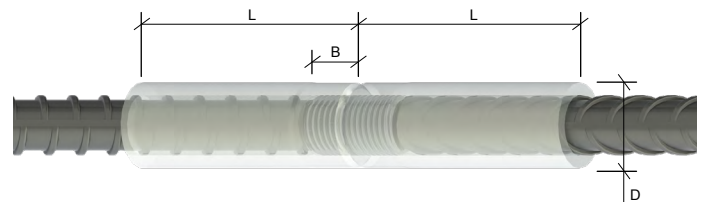
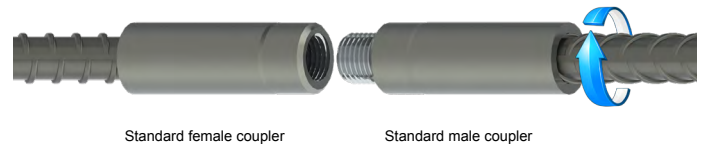

See Assembly instruction n° AI-GT05E.

Bar size	Model	Product code		Approximate dimensions (mm)		
		Female sleeve	Male sleeve	D	B	L
12	AG12	FPGS1214003	FPGS1214004	19	16	72
14	AG14	FPGS1416003	FPGS1416004	22	19	85
16	AG16	FPGS1618003	FPGS1618004	25	21	100
20	AG20N	FPGS2022005	FPGS2022006	31	25	110
24,25,26	AG25	FPGS2527005	FPGS2527006	38	26	120
28	G28	FPGS2830001	FPGS2830002	42	30	105
30,32	AG32N	FPGS3233003	FPGS3233004	47	40	140
36	AG36	FPGS3639001	FPGS3639002	54	41	143
40	AG40N	FPGS4042005	FPGS4042006	61	52	170
50	AG50N	FPGS5052003	FPGS5052004	72	71	225

Table 1: Dimensions of Griptec Standard splices.

Note: B is the distance between the face of the sleeve and the end of the bar inside the sleeve. The values of B and L are indicative, as they depend on the actual dimensions of the bar, its ribs and the shape of the cut.

# Transition Splices

When there is a need to splice bars of different sizes, the Griptec® connects two standard female sleeves with a two-stepped threaded stud.

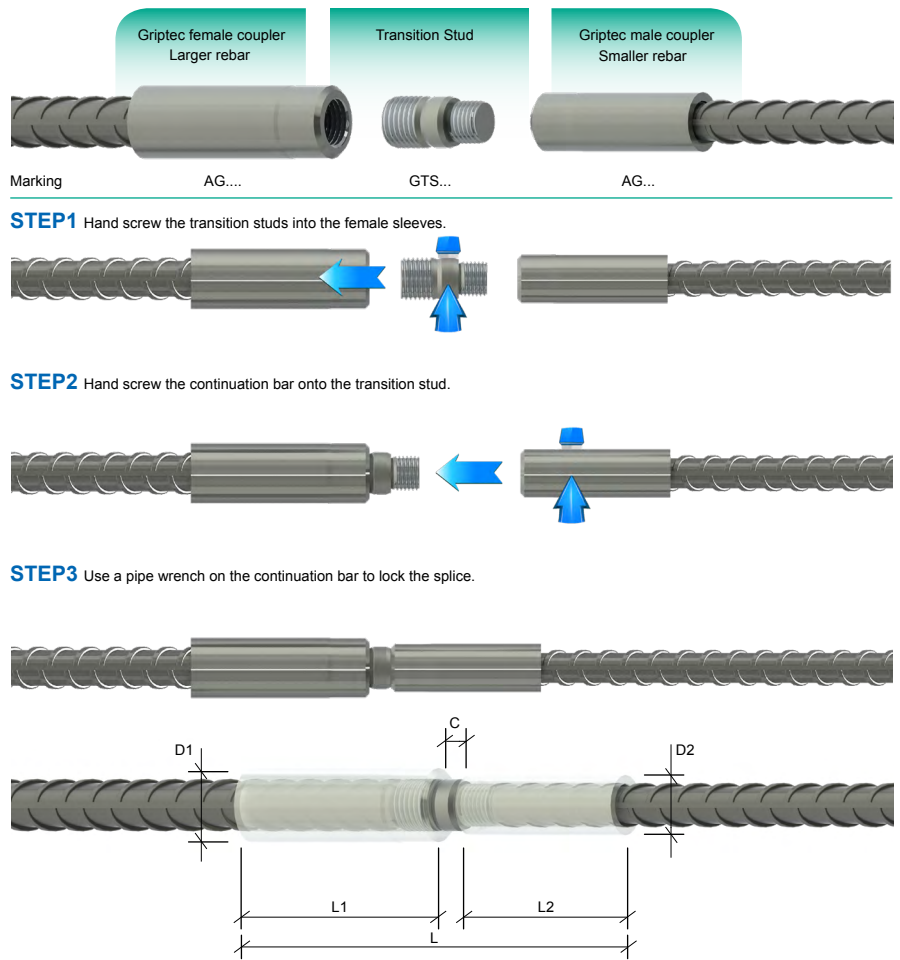

See Assembly instruction n° AI-GT09E.

Bar size D1/D2	Model	Product code Transition stud	Approximate dimensions (mm)					
			D1	D2	L1	L2	C	L
14/12	AGTS14/12	FPGT1412002	22	19	85	72	8	165
16/12	AGTS16/12	FPGT1612002	25	19	100	72	9	181
16/14	AGTS16/14	FPGT1614002	25	22	100	85	9	194
20/12	AGTS20/12	FPGT2012002	31	19	110	72	11	193
20/14	AGTS20/14	FPGT2014002	31	22	110	85	11	206
20/16	AGTS20/16	FPGT2016002	31	25	110	100	11	221
25/16	AGTS25/16	FPGT2516002	38	25	120	100	13.5	234
25/20	AGTS25/20	FPGT2520002	38	31	120	110	13.5	244
28/25	AGTS28/25	FPGT2825002	42	38	105	120	15	240
32/20	AGTS32/20	FPGT3220002	47	31	140	110	16.5	267
32/25	AGTS32/25	FPGT3225002	47	38	140	120	16.5	277
32/28	AGTS32/28	FPGT3228002	47	42	140	105	16.5	262
36/32	AGTS36/32	FPGT3632002	54	47	143	140	16.5	300
40/25	AGTS40/25	FPGT4025002	61	38	170	120	21	311
40/32	AGTS40/32	FPGT4032002	61	47	170	140	21	331
40/36	AGTS40/36	FPGT4036002	61	54	170	143	21	334
50/40	AGTS50/40	FPGT5040002	72	61	225	170	26	421

Note: Ordering information for the transition stud assembly / The table gives the product codes to mention in your purchase orders. Please note that the male and female sleeves have to be ordered separately.

Table 2: Griptec AGTS Transition splices

# Position Splices

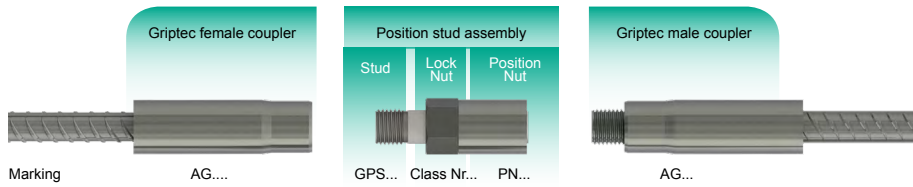

**STEP1** The position stud assembly is screwed into the female sleeve.



**STEP2** The male coupler is brought to contact with the position nut.

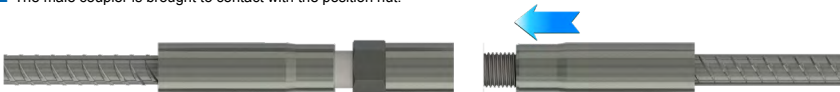

**STEP3** The position nut is screwed onto the male coupler.

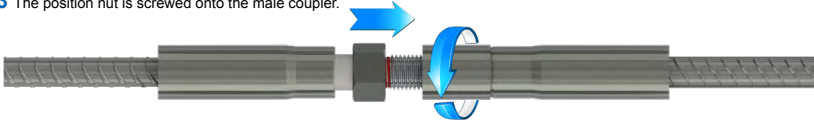

**STEP4** The lock nut is tightened against the position nut.

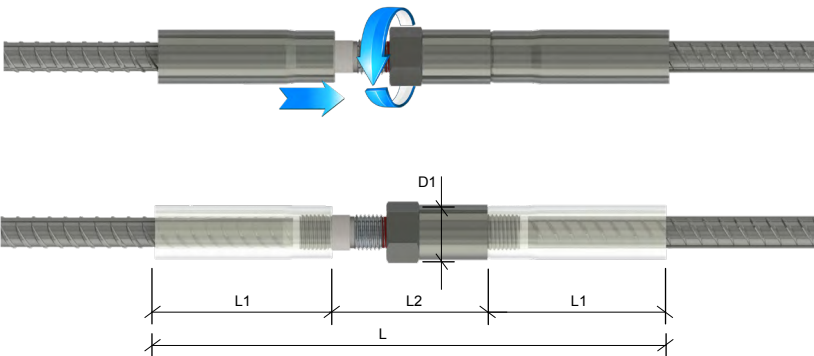

See Assembly instruction n° AI-GT17E

Bar size	Model	Product code Position stud assembly	Approximate dimensions (mm)			
			D1	L1	L2	L
12	GPC12	FPGP1214021	19	72	60	204
14	GPC14	FPGP1416021	24	85	69	239
16	GPC16	FPGP1618021	25	100	77	277
20	GPC20	FPGP2022021	34	110	94	314
24,25,26	GPC25	FPGP2527021	40	120	107	347
28	GPC28	FPGP2830021	44.5	105	119	329
30,32	GPC30	FPGP3233021	50	140	134	414
36	GPC36	FPGP3639021	56	143	150	436
40	GPC40	FPGP4042021	64	170	162	502
50	GPC50	FPGP5052021	80	225	213	663

Table 3: Griptec AGP Position splices & Lock nuts

Note: Ordering information for the position stud assembly / The table gives the product codes to mention in your purchase orders. Please note that the male and female sleeves have to be ordered separately.

When neither bar can be rotated (or if both bars would be a burden to rotate, for example because of their size, shape or length), the GRIPTEC® Position splice system uses a "Position stud assembly" set combined with standard male and female sleeves.

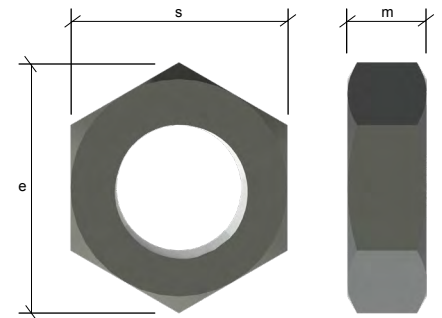
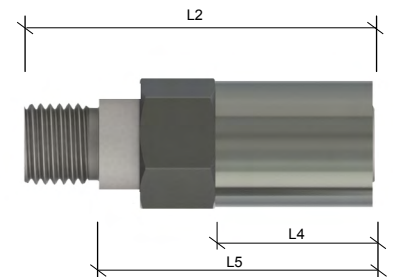

Dimensions of the position stud assembly:

Approximate dimensions (mm)					
L2	L4	L5	e	S	m
60	26	48	23	21	13
69	30	55	27	24	15
77	34	61	30	27	16
94	42	74	37	34	19
107	47	85	45	41	23
119	52	94	51	46	25
134	59	105	55	50	28
150	66	117	66	60	33
162	71	127	71	65	33
213	96	165	88	80	41

# Bridging Splices

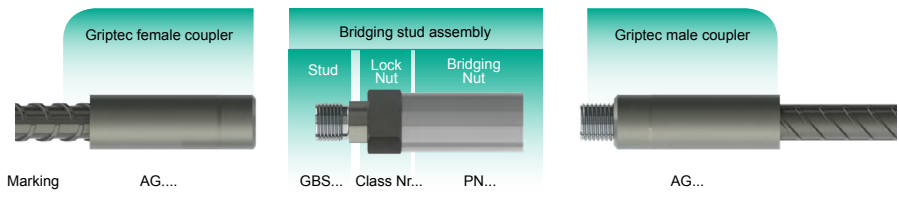

**STEP 1** The bridging stud assembly is screwed into the female sleeve.

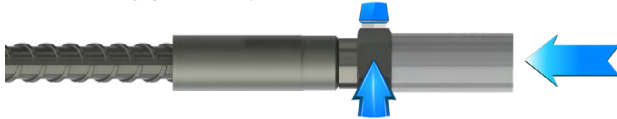

**STEP 2** The male coupler is brought as close as possible to the bridging nut.



**STEP 3** The bridging nut is screwed out of the bridging stud and onto the male coupler.

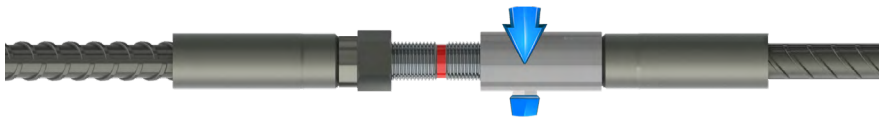

**STEP 4** The lock nut is tightened against the bridging nut.

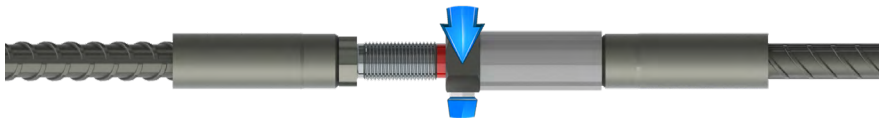

See Assembly instruction n° AI-GT19E

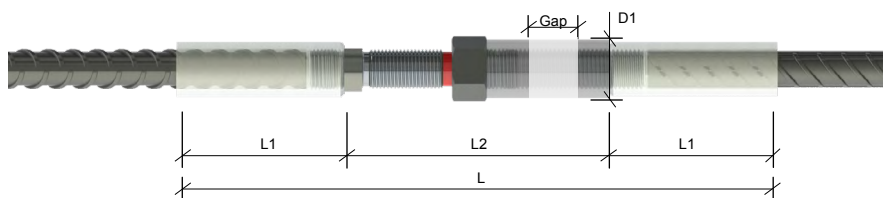

Overall dimensions of the splice

When the bars cannot be brought butt to butt (as it happens often in cages manufacturing), GRIPTEC® Bridging Splices are the answer. This is a variant of the position splice that uses a longer stud and a longer nut. Gaps between bar ends can be bridged by this system.

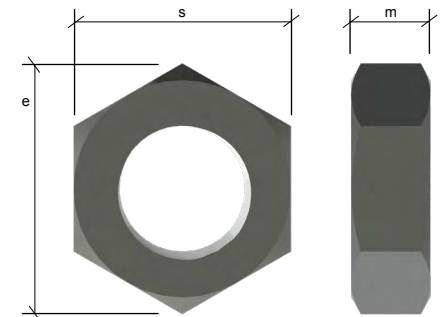
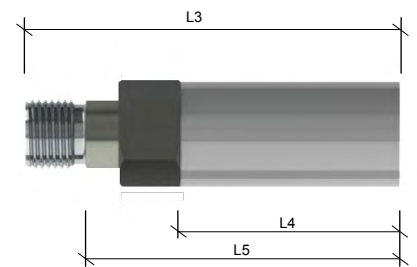

Dimensions of the bridging stud assembly

Bar size	Model	Product code	Approximate dimensions (mm)				
			D1	L1	L2	L	Gap
12	GPD12	FPGB1214001	19	72	131	275	35
14	GPD14	FPGB1416001	24	85	135	305	33
16	GPD16	FPGB1618001	25	100	150	350	36
20	GPD20	FPGB2022001	34	110	167	387	37
24,25,26	GPD25	FPGB2527005	40	120	196	436	45
28	GPD28	FPGB2830001	44.5	105	205	415	44
30,32	GPD32	FPGB3233005	50	140	220	500	44
36	GPD36	FPGB3639001	56	143	240	526	45
40	GPD40	FPGB4042001	64	170	254	594	47
50	GPD50	FPGB5052001	80	225	306	756	47

Table 4: Griptec AGB Bridging splices & Lock nuts

Note: Ordering information for the bridging stud assembly / The table gives the product codes to mention in your purchase orders. Please note that the male and female sleeves have to be ordered separately.

Approximate dimensions (mm)					
L3	L4	L5	e	S	m
96	59	84	23	21	13
102	61	88	27	24	15
114	68	98	30	27	16
130	77	110	37	34	19
151	89	129	45	41	23
164	97	136	51	46	25
176	101	148	55	50	28
195	110	163	66	60	32.6
207	117	172	71	65	33
259	143	211	88	80	41

# Headed Bars

Development or anchorage of reinforcement is the main use of headed bars. They conveniently replace hooked bars as end anchorages in congested areas. They can also be used to reduce lapping length, or as confinement or shear reinforcement where placing of stirrups is difficult.

Typical applications include exterior beam-column connections, roof corners, pile feet, pile caps, cantilevered members, corbels, etc.

Headed bars can provide full design anchorage by either the head bearing alone or a combination of the head bearing together and rebar bond. The selection of approach will primarily depend on the design standard adopted, the size of the head and the strength of concrete.

Standard GRIPTEC® mechanical anchorages are circular in shape and are fixed to the end of the rebar by screwing them onto the end of the male GRIPTEC® sleeve. Two sizes of heads are available:

- Small heads, with a net bearing area greater than or equal to four times the cross-section area of the reinforcing bar (4A).
- Large heads, with a net bearing area greater than or equal to nine times the cross-section area of the reinforcing bar (9A).

When loaded in tension and due to the round shape of the head, a cone of overstressed concrete will develop immediately under the head. If the head is large enough and the concrete is strong enough, the full anchorage design strength can be developed via the head alone. If this is not the case, then a contribution of rebar bond is required, immediately beyond the region of overstressed concrete.

Different codes of practice take different design approaches. Some, for example ACI 318, explicitly allow for a 4A head with a provision for a load contribution to be taken via rebar bond. Others, for example, fib Model Code 2010, give a set of simplified prescriptive rules for a minimum head size of 8A only. EN1992-1-1 (Eurocode 2), does not explicitly cover designing with headed bars. However, rules can be derived from the provisions for partially loaded areas. For further information on how to design in accordance with Eurocode 2, please see the Arup/Dextra Design Guide.

In beam-column connections, headed bars in beam reinforcement should extend to the far side of the column core. In roof corners, the column heads should be located above the beam bars. In both cases this detailing arrangement will provide space for an additional layer of transverse reinforcement, which will further improve the capacity of the anchorage.

Headed bars can be arranged close to one another: Tests have shown that the overlapping of compression cones does not reduce the effectiveness of the anchorage. However, the relevant code of practice should be followed with regards spacing.

For applications in seismic design, or whenever stress reversal can be expected, the anchorage length in compression should be checked too. (Just like hooks, headed bars do not contribute to anchorage in compression, which must therefore be provided by a straight portion of bar as per the code requirement).

Full-scale cyclic tests of beam-column connections reinforced with headed bars have shown that push-out of the concrete behind the head does not occur until a drift ratio of 6%.



$$\text{Surface ratio} = \frac{\text{Net bearing area}}{\text{Nominal bar cross section area}}$$





Standard Griptec anchor plates are circular, and are fixed to the bar end by screwing them onto male sleeve.



See Assembly instruction n° AI-GT14E.

### Small size Headed bars

Bar size	Model	Product code Small anchor plates	Approximate dimensions (mm)				Net bearing area (mm <sup>2</sup> )	Surface ratio
			D	T	L1	d		
12	AGEASC12	FPEC0414004	34	12	72	19	624	6
14	AGEASC14	FPEC1416004	38	14	85	22	747	5
16	AGEASC16	FPEC0518004	42	16	100	25	883	4
20	AGEASC20	FPEC0622004	52	20	110	31	1,369	4
24								5
25	AGEASC25	FPEC0827004	65	22	120	38	2,184	4
26								4
28	AGEASC28	FPEC2830254	70	25	105	42	2,483	4
30								5
32	AGEASC32	FPEC1033004	80	28	140	47	3,292	4
36	AGEASC36	FPEC1139004	90	32	143	54	4,072	4
40	AGEASC40	FPEC4042014	105	34	170	61	5,737	5
50	AGEASC50	FPEC5052004	125	47	225	72	8,200	4

Table 5 : Dimensions of Griptec small mechanical anchorages (Net bearing area at least 4 times the cross-section area of the bar)

### Large size Headed bars

Bar size	Model	Product code Large anchor plates	Approximate dimensions (mm)				Net bearing area (mm <sup>2</sup> )	Surface ratio
			D	T	L1	d		
12	AGEALC12	FPEC0414002	45	12	72	19	1,307	12
14	AGEALC14	FPEC1416002	50	14	85	22	1,576	10
16	AGEALC16	FPEC0518002	55	16	100	25	1,873	9
20	AGEALC20	FPEC0622002	70	20	110	31	3,094	10
24								12
25	AGEALC25	FPEC2527012	90	22	120	38	5,228	11
26								10
28	AGEALC28	FPEC2830002	95	25	105	42	5,722	9
30								11
32	AGEALC32	FPEC3233002	110	32	140	47	7,768	10
36	AGEALC36	FPEC1139002	125	32	143	54	9,982	10
40	AGEALC40	FPEC4042012	140	38	170	61	12,471	10
50	AGEALC50	FPEC5052002	170	47	225	72	18,627	9

Table 6 : Dimensions of Griptec large mechanical anchorages (Net bearing area at least 9 times the cross-section area of the bar)

For applications where the Griptec sleeve must be a female, it is possible to fix the end anchor plate with a hexagonal head screw

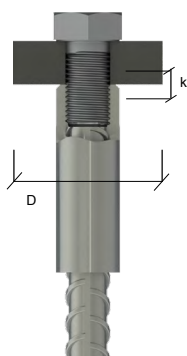

### Bolted Headed Bars

Bar size	Model	Product code bolted anchor set	Approximate dimensions (mm)					Net bearing area (mm <sup>2</sup> )	Surface ratio
			D	T	L1	d	k		
32	GEAB32	FPEC3200001	110	32	140	47	21	7,768	10
40	GEAB40	FPEC4000001	140	35	170	61	26	12,177	10

Table 7: Dimensions of Griptec mechanical anchorages for Griptec female sleeve. Consult us for bar diameters or head sizes other than those listed in this table. (Net bearing area at least 9 times the cross-section area of the bar)

# Weldable Couplers

For composite construction where concrete reinforcement bars must be welded to structural steel, GRIPTEC® weldable couplers are available. This is a nut made of weldable-grade steel that bears a large chamfer suitable for single bevel butt welding.

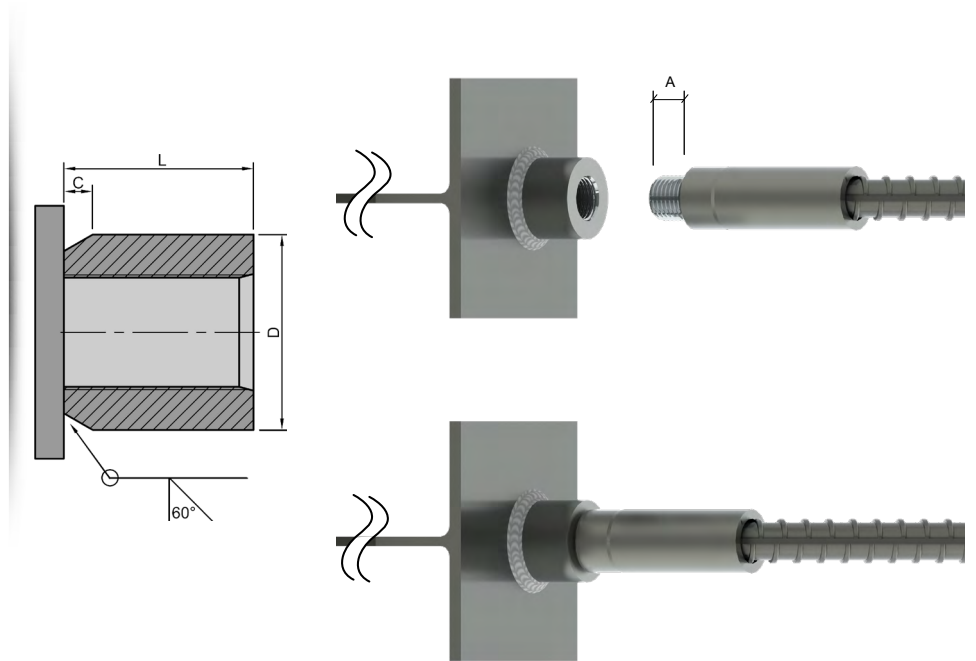

See Assembly instruction n° AI-CW01E.

Bar size	Model	Product code Weldable coupler	Approximate dimensions (mm)			
			D	L	A	C
12	WCM14	FPWC1214001	22	18	12	4
14	WCM16	FPWC1416001	28	27	14	4
16	WCM18	FPWC1618001	28	25	16	5
20	WCM22	FPWC1822001	38	35	20	5
24,25,26	WCM27	FPWC2627001	45	39	22	6
28	WRM30	FPWC3030001	50	45	25	5
30,32	WBM33	FPWC2833001	55	40	28	7
36	WCM39	FPWC3439001	65	47	32	8
40	WCM42	FPWC3642001	72	51	34	9
50	WCM52	FPWC5052001	85	52	47	10

Table 8: Dimensions of Griptec Weldable couplers

# Connection to Structural Steel

For composite construction where structural steel must be bolted to concrete reinforcement bars, GRIPTEC bridging nuts are available. These nuts are long enough to accommodate the Griptec male sleeve on one end and a standard bolt on the other end. The tables below indicate which bolt length and standard ISO-designation should be used, depending on the thickness of the structural steel (the 3 ranges of thickness are presented in 3 columns) and whether or not a washer is used (2 options presented in 2 separate tables).

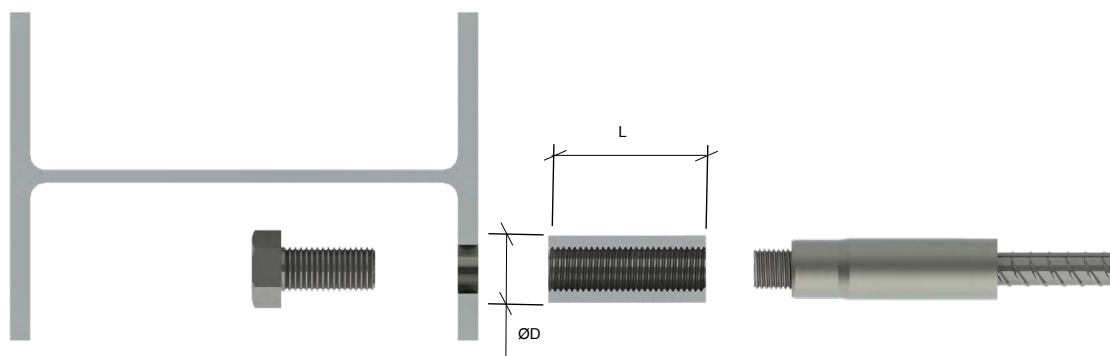

Bar size	Bridging nut details				Bolt details (as per ISO 4017 : 2014) without washer						
	Model	Product code	OD	L	Bolt class	Steel thickness 10mm to 35mm		Steel thickness 40mm to 60mm		Steel thickness 65mm to 90mm	
						Length	Designation : Hexagon head bolt ISO 4017	Length	Designation : Hexagon head bolt ISO 4017	Length	Designation : Hexagon head bolt ISO 4017
12	BN12	FPGB1214202	19	59	8.8	55	M14x55-8.8	80	M14x80-8.8		
14	BN14	FPGB1416202	24	61	8.8	55	M16x55-8.8	80	M16x80-	Not available	
16	BN16	FPGB1618252	25	68	8.8	60	M18x60-8.8	90	M18x90-8.8		
20	BN20	FPGB2022252	34	77	8.8	65	M22x65-8.8	90	M22x90-8.8	120	M22x120-8.8
25,26	BN25	FPGB2527302	40	89	8.8	70	M27x70-8.8	100	M27x100-8.8	130	M27x130-8.8
30,32	BN32	FPGB3233352	50	101	10.9	80	M33x80-10.9	110	M33x110-10.9	130	M33x130-10.9
36	BN36	FPBG3639402	56	110	8.8	80	M39x80-8.8	110	M39x110-8.8	140	M39x140-8.8
40	BN40	FPGB4042452	64	117	10.9	90	M42x90-10.9	120	M42x120-10.9	140	M42x140-10.9
50	BN50	FPGB5057502	80	143	10.9	100	M52x100-10.9	130	M52x130-10.9	160	M52x160-10.9

Table 9 : Dimensions of Structural connection - Bolt designation - Without washer

Bar size	Bridging nut details				Hexagon head screw details (as per ISO 4017 : 2014) with washer (as per ISO 7089 : 2000)						
	Model	Product code	OD	L	Bolt class	Steel thickness 10mm to 35mm		Steel thickness 40mm to 60mm		Steel thickness 65mm to 90mm	
						Length	Designation : Hexagon head bolt ISO 4017	Length	Designation : Hexagon head bolt ISO 4017	Length	Designation : Hexagon head bolt ISO 4017
12	BN12	FPGB1214202	19	59	8.8	55	M14x55-8.8	90	M14x90-8.8		
14	BN14	FPGB1416202	24	61	8.8	60	M16x60-8.8	90	M16x90-8.8	Not available	
16	BN16	FPGB1618252	25	68	8.8	60	M18x60-8.8	90	M18x90-8.8		
20	BN20	FPGB2022252	34	77	8.8	65	M22x65-8.8	90	M22x90-8.8	120	M22x120-8.8
25,26	BN25	FPGB2527302	40	89	8.8	70	M27x70-8.8	110	M27x110-8.8	130	M27x130-8.8
30,32	BN32	FPGB3233352	50	101	10.9	80	M33x80-10.9	110	M33x110-10.9	140	M33x140-10.9
36	BN36	FPBG3639402	56	110	8.8	90	M39x90-8.8	120	M39x120-8.8	150	M39x150-8.8
40	BN40	FPGB4042452	64	117	10.9	100	M42x100-10.9	130	M42x130-10.9	150	M42x150-10.9
50	BN50	FPGB5057502	80	143	10.9	110	M52x110-10.9	140	M52x140-10.9	160	M52x160-10.9

Table 10 : Dimensions of Structural connection - Bolt designation - With washer

# Pocket Formers

Pocket Formers are plastic accessories that fit the threads of male Griptec® sleeves in order to form a reservation in the concrete. They can be nailed to a wooden formwork through the holes in their flange.

It is advisable to apply a mould-release agent to the pocket formers prior to concreting. Simply use the same agent as for the formworks.

Simple extraction tools are available on request

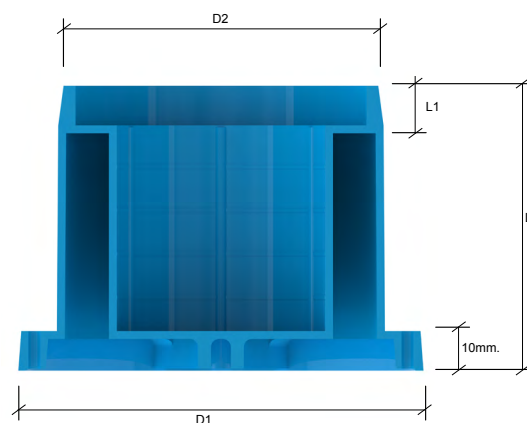
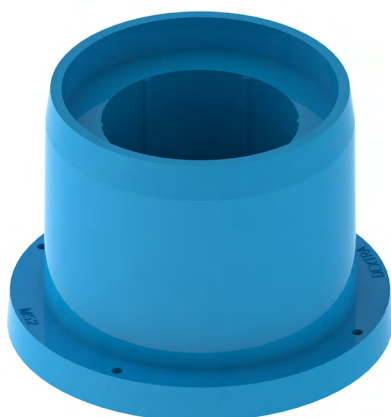
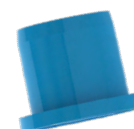
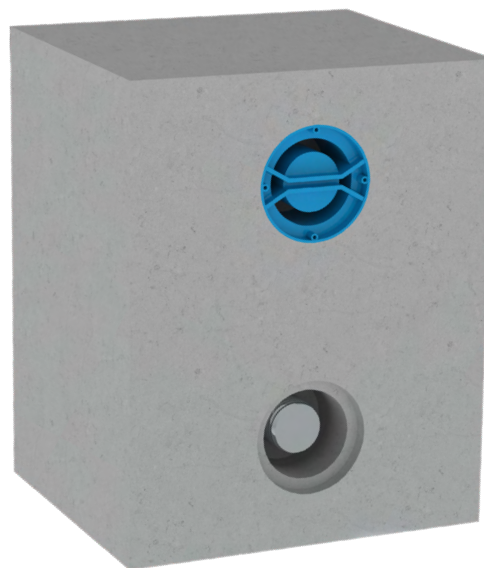

Bar size	Model	Product code Pocker Former	Approximate dimensions (mm)			
			D1	D2	L	L1
40	PFM42	FPPF4042001	91	71	59	10
50	PFM52	FPPF5052001	103	82	72	10

Table 11: Dimensions of Griptec Pocket Formers

# Nailing Plate

Nailing Plates are plastic accessories that are used to fix female Griptec couplers on timber formwork. This is done by nailing the plate to the formwork at the desired location and then screw the coupler onto the plate.

After removing the formwork, the nailing plate is unscrewed, leaving a 10 to 12 mm deep recess between the concrete surface and the female coupler.

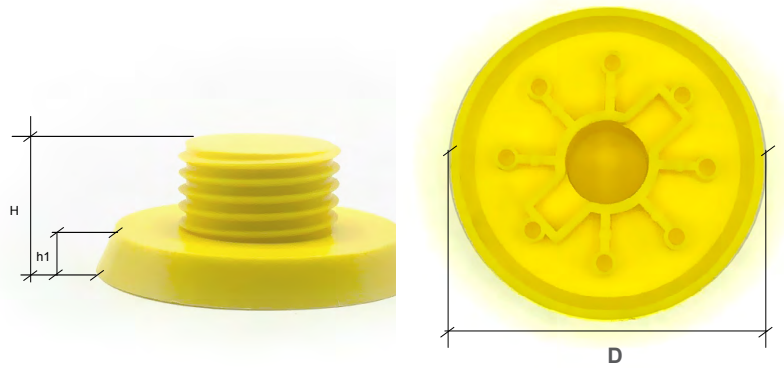

Bar size	Product code	Approximate dimensions (mm)		
		D	H	h1
12	GACC3700001	40	20	10
14	GACC3700002	40	20	
16	GACC3700003	55	25	
20	GACC3700004	55	25	
24,25,26	GACC3700005	55	25	
28	GACC3700006	70	30	
30, 32	GACC3700007	70	30	12
36	GACC3700008	70	30	
40	GACC3700009	95	34	
50	GACC3700010	95	34	

Table 12: Dimensions of Griptec Nailing plates (colour may varies).

# Stainless Steel Connectors

Stainless steel connectors are available for future extensions : Their blind holes prevent water ingress and their material prevents corrosion to occur, thereby maintaining the reinforcement in good condition until the day the extension is built. They are made of grade 316Ti as per ASTM A276 or X6CrNiMoTi17-12-2 as per EN 10088-3.

Bar size	Model	Product code Stainless steel connectors	Approximate dimensions (mm)	
			ØD	L
12	ECG12	FPSC1214001	23	45
14	ECG14	FPSC1416001	27	50
16	ECG16	FPSC1618001	30	55
20	ECG20	FPSC2022001	38	60
25,26	ECG25	FPSC2527001	47	65
30,32	ECG32	FPSC3233001	59	85
40	ECG40	FPSC4042001	74	95

Table 13 : Dimensions of Stainless steel connectors

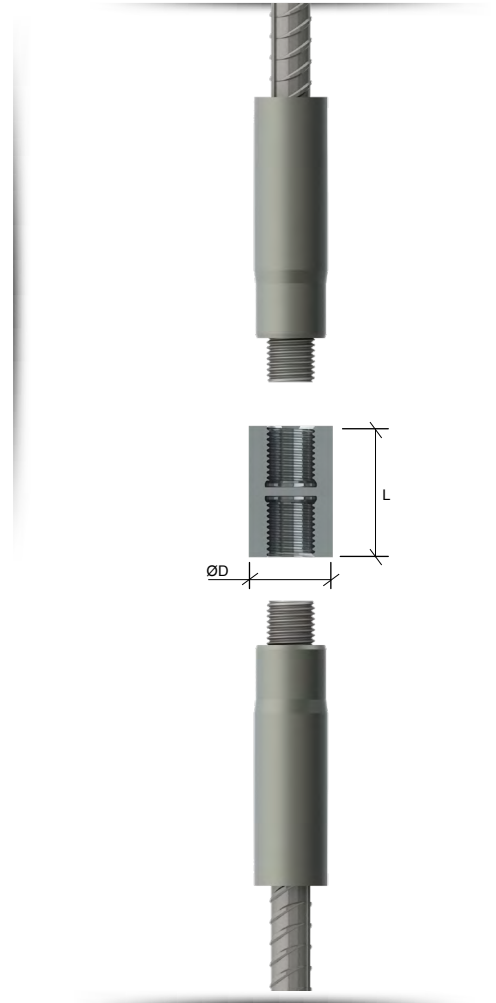

# Colour Identification

The plastic caps that protect the threads of GRIPTEC® couplers are coloured to enable a quick identification of the bar size and prevent miss-matching of threads.

Bar size	Thread size	Colour
12	M14x2.0	Yellow
14	M16x2.0	Blue
16	M18x2.5	White
20	M22x2.5	Grey
24,25,26	M27x3.0	Red
28	M30x2.5	Black
30,32	M33x3.5	Brown
36	M39x4.0	Yellow
40	M42x4.5	Green
50	M52x5.0	Grey

Table 15: Colour of plastic caps

# Installation

Contrary to taper threads, no torque wrench is necessary. Connections on site must be done as per the correct Assembly Instruction, as referenced in this document for each type of splice. They are available upon request or at [www.dextragroup.com/downloads](http://www.dextragroup.com/downloads)

# Custom Code

The usual international customs code for mechanical couplers and anchor plates is 73.08.90.90.00-7 ("Parts of structures, of iron or steel").

However, national preferences may be followed.

# Quality Assurance

Griptec® couplers and anchor plates are manufactured according to strict technical specifications and under a production process that has been certified to satisfy to ISO 9001 and ASME NCA-3800 quality assurance standards. This quality assurance system complies with the requirements ASME NQA-1 and 10CFR50 Appendix B.

They are warranted to be free from manufacturing defects and to perform in accordance with the manufacturer's specifications providing that they are installed in accordance with the manufacturer's instructions.

Agency	Certificate N°
 The American Society of Mechanical Engineers	QSC-706
 Bureau Veritas ISO 9001:2015	TH010882
 UK CARES ISO 9001:2015	1086

Table 14: Quality assurance



Full trace-ability of the production batches and raw materials is guaranteed for all load-bearing components. The retention period of our quality records is 12 years.

# Approvals

Griptec® splices have received the following approvals:















Country	Agency	Certificate N°	Details
	 <b>AFCAB</b> ASSOCIATION FRANÇAISE DE CERTIFICATION DES ARMATURES DU BÉTON	N° M02/004	For standard, position, bridging, transition & position-transition splices and anchorages in dia 12 through 40. For standard fatigue in dia 12 through 32. For Standard, bridging seismic in dia 12 through 40.
		N° 5005 for BS 8110 and Eurocode2 applications	For standard, position & transition splices in dia 12 through 50. For position-transition splices in dia 12 through 40. For bridging splices in dia 16 through 50. For caging splices in dia 32 through 50.
		N° 5014 for Sellafeld applications	For standard & position splices in dia 12 through 50. For transition & bridging splices in dia 16 through 50. For caging splices, and bridging transition in dia 32 through 40.
		N° 5051 for Highways Agency applications	For standard splices in dia 16 through 40. For position splices in dia 32 & 40.
		N° 5059 for BS8110 & Eurocode 2 applications	For small anchors bars in dia 16 through 40 For large bars in dia 16 through 32, and Bolted Headed bars in dia 32 through 40.
		N° 5059 for Sellafeld applications	For small anchors bars in dia 16 through 40 For large bars in dia 16 through 25, and Bolted Headed bars in dia 32 through 40.
	 <b>Deutsches Institut für Bautechnik</b>	N° Z-1.5-133	For standard, position, bridging, transition & position-transition splices, anchorages, weldable, stainless steel connectors, and steel connectors in dia 12 through 40.
	 <b>bmvt</b> Austrian Ministry for Transport, Innovation and Technology	N° 327.120/0007-IV/IVVS2/2016	For standard splices in dia 12 through 36
	 <b>Transport</b> Roads & Maritime Services	N° SF2016/39582	For standard splices in dia 12 through 40.

Table 16: Approvals certificate

# Changes and Updates

As a result of our continuous thrive for technological improvement, Dextra reserves its right to modify the contents of this specification sheet at any time without prior notice.

# Disclaimer

Dextra products are warranted to be free from defects in material and workmanship at the time of delivery. No other warranty, whether expressed or implied shall exist in the connection of the sale, lease or use of any Dextra products. This warranty is limited to the original value of the products/ services.

Dextra shall in no event be responsible if the products have not been stored or used in accordance with its specifications and recommended procedures / instructions.

Dextra is not responsible for any direct or consequential losses or damages of any kind that maybe incurred by the Buyer/User of its products.



# PACKING DETAILS



# Packing details

Pocket formers are packed in carton boxes. Other products are packed in wooden crates that can be lifted by a forklift.

All products must be stored under a roof and protected from the elements.

*Please ensure that order quantities are a multiple of the packaging quantities stated in the following tables.*

Box type	Inside	Outside	Weight (kg)
	W x L x H (cm)	W x L x H (cm)	
1	36.6x56.6x25.0	43.4x63.4x43.7	17
2	56.6x76.6x29.0	63.4x83.4x47.7	25
3	76.6x116.6x29.0	83.4x123.4x47.7	39
4	76.6x116.6x45.0	83.4x123.4x63.7	48
5	76.6x116.6x65.0	83.4x123.4x83.7	60

#### Wooden crates dimensions

*Note: The weight of the crates varies depending on ambient humidity.*

Carton box for	Carton box size (cm)	Weight (kg)
Pocker former	40x40x40	1

#### Carton boxes dimensions

*Note: The weight of the crates varies depending on ambient humidity.*

Bar size	Model	Product code	Qty (pcs)	Box type	Net weight (kg)	Gross weight (kg)
		Female sleeve				
12	AG12	FPGS1214003	500	1	45	62
14	AG14	FPGS1416003	500	1	65	82
16	AG16	FPGS1618003	500	1	110	127
20	AG20N	FPGS2022005	500	2	160	185
24,25,26	AG25	FPGS2527005	500	3	265	304
28	G28	FPGS2830001	500	3	280	319
30,32	AG32N	FPGS3233003	500	3	485	524
36	AG36	FPGS3639001	250	3	345	384
40	AG40N	FPGS4042005	250	3	505	544
50	AG50N	FPGS5052003	100	3	376	415

Bar size	Model	Product code	Qty (pcs)	Box type	Net weight (kg)	Gross weight (kg)
		Male sleeve				
12	AG12	FPGS1214004	500	1	55	72
14	AG14	FPGS1416004	500	1	85	102
16	AG16	FPGS1618004	500	1	135	152
20	AG20N	FPGS2022006	500	2	210	235
24,25,26	AG25	FPGS2527006	500	3	350	389
28	G28	FPGS2830002	500	3	405	444
30,32	AG32N	FPGS3233004	500	3	650	689
36	AG36	FPGS3639002	250	3	478	517
40	AG40N	FPGS4042006	250	4	668	716
50	AG50N	FPGS5052004	100	3	517	556

Bar size	Model	Product code	Qty (pcs)	Box type	Net weight (kg)	Gross weight (kg)
14/12	AGTS14/12	FPGT1412002	1000	1	50	67
16/12	AGTS16/12	FPGT1612002	1000	1	70	87
16/14	AGTS16/14	FPGT1614002	1000	1	70	87
20/12	AGTS20/12	FPGT2012002	500	1	60	77
20/14	AGTS20/14	FPGT2014002	500	1	60	77
20/16	AGTS20/16	FPGT2016002	500	1	65	82
25/16	AGTS25/16	FPGT2516002	500	1	105	122
25/20	AGTS25/20	FPGT2520002	500	1	120	137
28/25	AGTS28/25	FPGT2825002	500	2	175	200
32/20	AGTS32/20	FPGT3220002	500	2	190	215
32/25	AGTS32/25	FPGT3225002	500	2	210	235
32/28	AGTS32/28	FPGT3228002	500	2	230	255
36/32	AGTS36/32	FPGT3632002	250	2	160	185
40/25	AGTS40/25	FPGT4025002	250	2	185	210
40/32	AGTS40/32	FPGT4032002	250	2	208	233
40/36	AGTS40/36	FPGT4036002	250	2	233	258
50/40	AGTS50/40	FPGT5040002	100	2	184	209

Bar size	Model	Product code	Qty (pcs)	Box type	Net weight (kg)	Gross weight (kg)
12	GPC12	FPGP1214021	200	1	24	41
14	GPC14	FPGP1416021	200	1	40	57
16	GPC16	FPGP1618021	200	1	48	65
20	GPC20	FPGP2022021	200	1	106	123
24,25,26	GPC25	FPGP2527021	200	2	174	199
28	GPC28	FPGP2830021	200	2	242	267
30,32	GPC30	FPGP3233021	200	2	330	355
36	GPC36	FPGP3639021	200	3	496	535
40	GPC40	FPGP4042021	200	3	772	811
50	GPC50	FPGP5052021	100	3	666	705

Bar size	Model	Product code	Qty (pcs)	Box type	Net weight (kg)	Gross weight (kg)
12	GPD12	FPGB1214001	200	1	40	57
14	GPD14	FPGB1416001	200	1	62	79
16	GPD16	FPGB1618001	200	1	78	95
20	GPD20	FPGB2022001	200	1	158	175
24,25,26	GPD25	FPGB2527005	200	2	262	287
28	GPD28	FPGB2830001	200	2	352	377
30,32	GPD32	FPGB3233005	200	3	466	505
36	GPD36	FPGB3639001	200	3	678	717
40	GPD40	FPGB4042001	200	3	898	937
50	GPD50	FPGB5052001	100	3	862	901

Bar size	Model	Product code	Qty (pcs)	Box type	Net weight (kg)	Gross weight (kg)
12	AGEASC12	FPEC0414004	500	1	40	57
14	AGEASC14	FPEC1416004	500	1	55	72
16	AGEASC16	FPEC0518004	500	1	75	92
20	AGEASC20	FPEC0622004	500	1	145	162
24,25,26	AGEASC25	FPEC0827004	500	2	250	275
28	AGEASC28	FPEC2830254	500	2	320	345
32	AGEASC32	FPEC1033004	500	3	505	544
36	AGEASC36	FPEC1139004	500	3	710	749
40	AGEASC40	FPEC4042014	500	4	1,055	1,103
50	AGEASC50	FPEC5052004	250	4	1,003	1,051

Bar size	Model	Product code	Qty (pcs)	Box type	Net weight (kg)	Gross weight (kg)
12	AGEALC12	FPEC0414002	500	1	70	87
14	AGEALC14	FPEC1416002	500	1	100	117
16	AGEALC16	FPEC0518002	500	2	140	165
20	AGEALC20	FPEC0622002	500	2	285	310
24,25,26	AGEALC25	FPEC2527012	500	3	555	594
28	AGEALC28	FPEC2830002	250	2	343	368
30,32	AGEALC32	FPEC3233002	200	2	470	495
36	AGEALC36	FPEC1139002	250	3	753	792
40	AGEALC40	FPEC4042012	200	3	894	933
50	AGEALC50	FPEC5052002	100	3	804	843

Bar size	Model	Product code	Qty (pcs)	Box type	Net weight (kg)	Gross weight (kg)
32	GEAB32	FPEC3200001	200	3	608	647
40	GEAB40	FPEC4000001	200	3	1,124	1,163

Bar size	Model	Product code	Qty (pcs)	Box type	Net weight (kg)	Gross weight (kg)
12	WCM14	FPWC1214001	250	1	10	27
14	WCM16	FPWC1416001	250	1	25	42
16	WCM18	FPWC1618001	250	1	20	37
20	WCM22	FPWC1822001	250	1	58	75
24,25,26	WCM27	FPWC2627001	250	1	85	102
28	WRM30	FPWC3030001	250	1	123	140
30,32	WBM33	FPWC2833001	250	2	130	155
36	WCM39	FPWC3439001	250	2	210	235
40	WCM42	FPWC3642001	250	2	288	313
50	WCM52	FPWC5052001	250	3	385	424

Bar size	Model	Product code	Qty (pcs)	Box type	Net weight (kg)	Gross weight (kg)
12	BN12	FPGB1214202	1000	1	70	87
14	BN14	FPGB1416202	1000	2	130	155
16	BN16	FPGB1618252	1000	2	150	175
20	BN20	FPGB2022252	1000	3	350	389
25,26	BN25	FPGB2527302	1000	3	530	569
30,32	BN32	FPGB3233352	500	3	480	519
36	BN36	FPBG3639402	500	4	610	658
40	BN40	FPGB4042452	250	3	463	502
50	BN50	FPGB5057502	200	4	708	756

Bar size	Model	Product code	Qty (pcs)	Carton box	Net weight (kg)	Gross weight (kg)
40	PFM42	FPPF4042001	100	40x40x40	8	9
50	PFM52	FPPF5052001	100	40x40x40	11	12

Note: FCL shipments may be palletized, whereas LCL shipments must be boxed.

Bar size	Model	Product code	Qty (pcs)	Box type	Net weight (kg)	Gross weight (kg)
12	ECG12	FPSC1214001	1000	1	170	187
14	ECG14	FPSC1416001	1000	2	240	265
16	ECG16	FPSC1618001	1000	2	310	335
20	ECG20	FPSC2022001	500	2	250	275
25,26	ECG25	FPSC2527001	250	2	205	230
30, 32	ECG32	FPSC3233001	100	1	172	189
40	ECG40	FPSC4042001	100	2	276	301



Commercial presence in more than 55 countries.



**HEADQUARTERS THAILAND**  
**Dextra Manufacturing Co., Ltd.**  
 Tel: (66) 2 021 3800  
 Fax: (66) 2 328 0374  
 E-mail: thailand@dextragroup.com



**EUROPE**  
**Dextra Europe SARL.**  
 Tel: (33) 1 45 53 70 82  
 Fax: (33) 1 47 04 28 97  
 E-mail: europe@dextragroup.com



**NORTH AMERICA**  
**Dextra America Inc.**  
 Tel: (1) 805 915 4734 / 818 261 5166  
 E-mail: america@dextragroup.com



**CHINA**  
**Dextra Building Products**  
**(Guangdong) Co., Ltd.**  
 Tel: (86) 20 2261 9901  
 Fax: (86) 20 2261 9902  
 E-mail: china@dextragroup.com



**MIDDLE EAST**  
**Dextra Middle-East FZE**  
 Tel: (971) 4886 5620  
 Fax: (971) 4886 5621  
 E-mail: middleeast@dextragroup.com



**LATIN AMERICA**  
**Dextra Latam**  
 Tel: (507) 6454 8100 / 831 1442  
 E-mail: latam@dextragroup.com



**HONG KONG**  
**Dextra Pacific Ltd.**  
 Tel: (852) 2845 7766 / 2511 8236  
 Fax: (852) 2586 1656 / 2519 0852  
 E-mail: dplbuilding@dextragroup.com



**INDIA**  
**Dextra India Pvt. Ltd.**  
 Tel: (91) 22 2838 6294 / 22 2839 2694  
 Fax: (91) 22 2839 2674  
 E-mail: india@dextragroup.com



**SOUTH AMERICA**  
**Dextra do Brasil**  
 Tel: (55) 11 5505 2475 / 11 5505 2477  
 E-mail: brasil@dextragroup.com

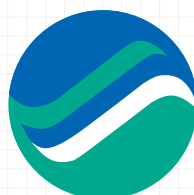

**Dextra**  
[www.dextragroup.com](http://www.dextragroup.com)