

CARES Technical Approval Report TA1-B 5042

Issue 4



Dextra

ROLLTEC®

**Dextra
ROLLTEC Standard, Positional
and Caging Couplers**

Assessment of the
Dextra ROLLTEC Standard,
Positional and Caging
Coupler Product
and Quality System
for Production



TECHNICAL
APPROVAL



UKAS
PRODUCT
CERTIFICATION

5042

Product

Dextra ROLLTEC
Standard, Positional
and Caging Couplers
for reinforcing steel.

Product approval held by:

DEXTRA Manufacturing Co. Ltd,
5th Floor Lumpini II Building
247 Sarasin Road
Lumpini Pathumwan
Bangkok 10330
Thailand

Tel: +66 2651 9027 Fax: +66 2651 8000

1 Product Summary

Dextra ROLLTEC Standard Couplers in the size range 12mm - 40mm, Positional in the size range 12mm - 32mm and Caging Couplers in the 40mm size range are for the mechanical connection of deformed high yield carbon steel bars for the reinforcement of concrete complying with the requirements of BS4449 Grade B500C and BS4449 Grade B500B.

1.1 Scope of Application

Dextra ROLLTEC Standard Couplers in the size range 12mm - 40mm, Positional in the size range 12mm - 32mm and Caging Couplers in the 40mm size range have been evaluated for use as follows:

- a) TA1-B: EC2 and BS8110 for static applications in tension only with Grade B500C reinforcement.
- b) TA1-B: EC2 and BS8110 for static applications in tension only with Grade B500B reinforcement.

1.2 Design Considerations

BS8110 Clause 3.12.8.9 Laps and Joints states "Connections transferring stress may be lapped, welded or joined with mechanical devices. They should be placed, if possible, away from points of high stress and should preferably be staggered". However, BS8110 Clause 3.12.8.16.2 Bars in tension states "The only acceptable form of full-strength butt joint for a bar in tension comprises a mechanical coupler" satisfying specified slip and tensile strength criteria.



Eurocode 2, Clause 8.7 Laps and mechanical couplers 8.7.1 General (1)P "Forces are transmitted from one bar to another by:

- lapping of bars, with or without bends or hooks;
- welding;
- mechanical devices assuring load transfer in tension-compression or in compression only."

Clause 8.8 Additional rules for large diameter bars goes on to state that "Splitting forces are higher and dowel action is greater with the use of large diameter bars. Such bars should be anchored with mechanical devices."

The specified cover for fire resistance and durability should be provided to the coupler sleeve. All couplers have been designed with controlled mechanical properties to be compatible with reinforcing bars complying with reinforcement of the relevant Grade in accordance with BS4449.

1.3 Conclusion

It is the opinion of CARES that Dextra ROLLTEC Standard Couplers in the size range 12mm - 40mm, Positional in the size range 12mm - 32mm and Caging Couplers in the 40mm size range are satisfactory for use within the limits stated in paragraph 1.1 when applied and used in accordance with the manufacturer's instructions and the requirements of this certificate.

Lee Brankley
 L. Brankley
 Chief Executive Officer

August 2017



2 Technical Specification

The function of Dextra ROLLTEC Standard, Positional and Caging Couplers is to connect deformed steel reinforcing bars complying with BS4449 Grade B500C and BS4449 Grade B500B as appropriate and thereby create structural continuity of the reinforcing system.

2.1 ROLLTEC Standard Couplers

The ROLLTEC Standard Coupler range is designed for use where one of the bars to be spliced can be rotated. The reinforcing bar end preparation system consists in rolling a thread at the end of the bar and is done in only one operation. The standard coupler comprises a standard female coupler with internal parallel thread matching the thread size made on the bars.

ROLLTEC Standard Coupler

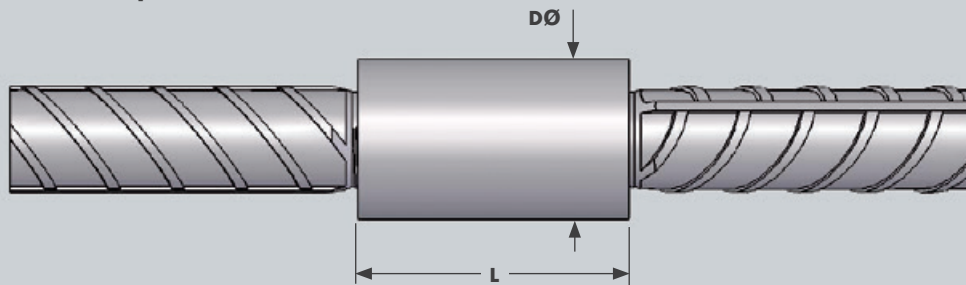

Size mm	Art No	D (mm)	L (mm)	Thread (mm)	Weight (kg)	Plastic protection colour
12	FPRS1213001	20	38	M13 x 1.5	0.06	Black
16	FPRS1617001	26	45	M17 x 1.75	0.11	White
20	FPRS2021001	32	55	M21 x 2.0	0.22	Grey
25	FPRS2526001	40	65	M26 x 2.5	0.41	Red
32	FPRS3233001	50	85	M33 x 3.0	0.81	Brown
40	FPRS4041001	65	100	M41 x 3.0	1.68	Green

Table 1

2.2 ROLLTEC Positional Range

The ROLLTEC Positional Coupler range is designed to be used when both bars would be difficult to rotate. The thread on the bar has been extended, thereby enabling the coupler to be fully screwed onto it. The position coupler comprises two components: a standard female coupler and a lock nut. The applied lock nut can be either hexagonal shape or round shape.

ROLLTEC Positional Coupler using hexagonal lock nut

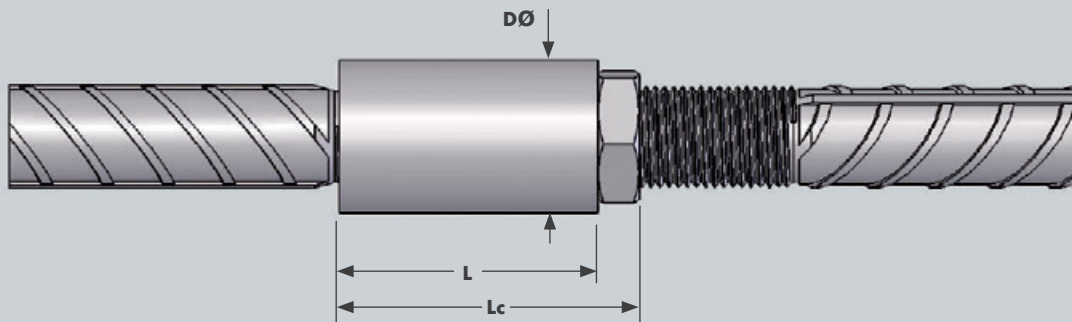

ROLLTEC Positional Coupler using round lock nut

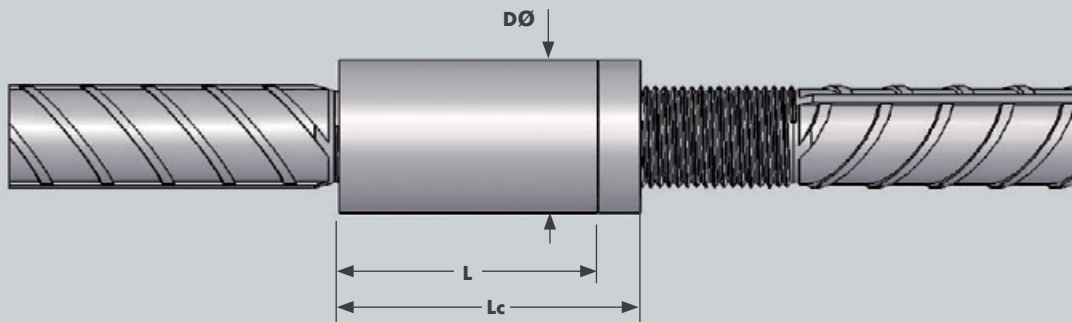

Size mm	Art No	D (mm)	L (mm)	Lc (mm)		Thread (mm)	Weight (kg)	Plastic protection colour
				Hex	Round			
12	FPRS1213001	20	38	43	48	M13 x 1.5	0.07	Black
16	FPRS1617001	26	45	52	55	M17 x 1.75	0.12	White
20	FPRS2021001	32	55	64	65	M21 x 2.0	0.32	Grey
25	FPRS2526001	40	65	77	77	M26 x 2.5	0.45	Red
32	FPRS3233001	50	85	99	99	M33 x 3.0	0.89	Brown

Table 2

Electronic Copy www.ukcares.com



2.3 ROLLTEC Caging Coupler

The ROLLTEC Caging Coupler range is designed for applications where the bars cannot be brought to butt. Both bars are threaded with a standard ROLLTEC thread, and a "caging assembly set" is used to connect them. This set comprises of 3 pieces pre-assembled together: a long caging coupler, a caging stud, and a lock-nut. The end of the bridging stud bears a female thread that fits on one bar (Preferably the top bar in case of vertical assemblies). The lock nut applied can be either hexagonal or round in shape.

ROLLTEC Caging Coupler using hexagonal lock nut

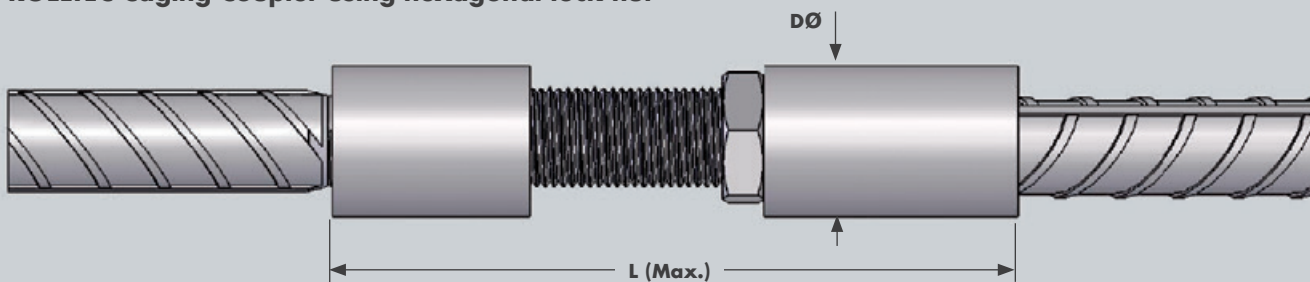

ROLLTEC Caging Coupler hexagonal assembly set

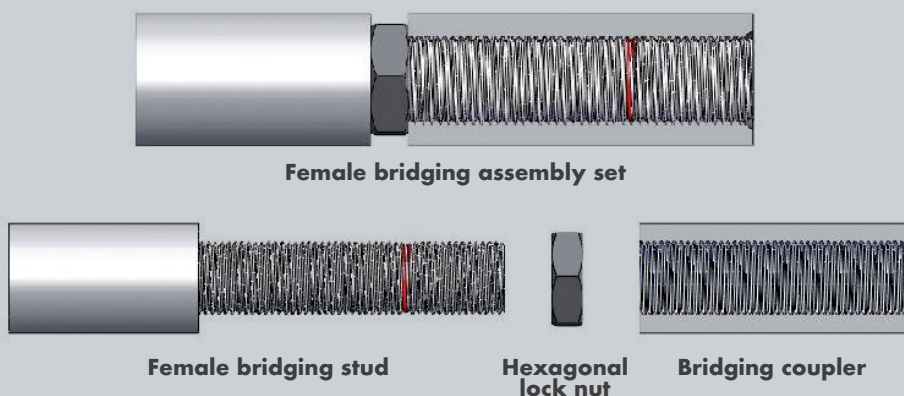

Size mm	Art No	D (mm)	L (mm)	Thread (mm)	Weight (kg)	Plastic protection colour
40	FPRB4041003	65	358	M41 x 3.0	5.68	Green

Table 3

ROLLTEC Caging Coupler using round lock nut

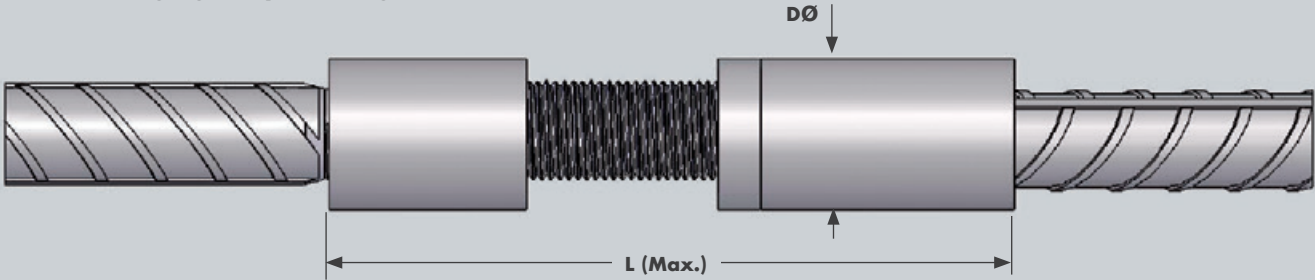

ROLLTEC Caging Coupler round assembly set

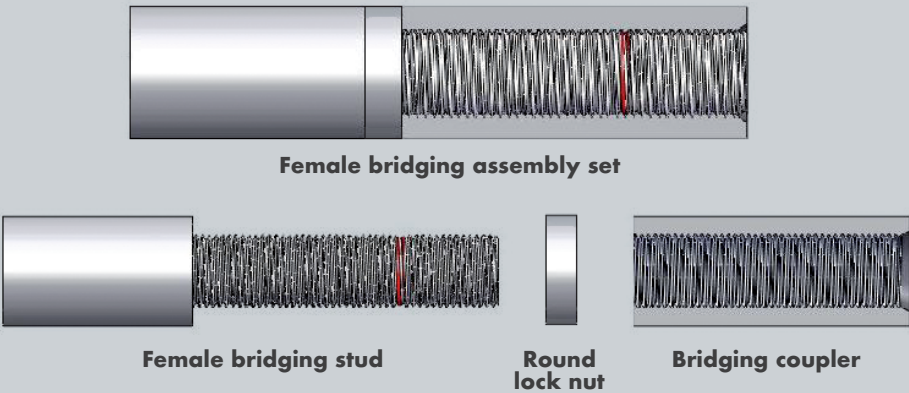

Size mm	Art No	D (mm)	L (mm)	Thread (mm)	Weight (kg)	Plastic protection colour
40	FPRB4041003	65	358	M41 x 3.0	5.68	Green

Table 4

Electronic Copy www.ukcares.com



3 Product Performance and Characteristics

Full destructive tests have been carried out to demonstrate compliance with the performance requirements defined in CARES Appendix TA1-B when used with reinforcing steel BS4449 Grade B500C and BS4449 Grade B500B:

CARES APPENDIX TA1-B strength requirements

- Permanent elongation is less than 0.10mm or effective strain of less than 0.0016 at a load of $0.65f_y$ in tension.
- 99% characteristic tensile strength is greater than 575MPa with B500C reinforcing steel and greater than 540MPa with grade B500B reinforcing steel in tension.

4 Installation

The bars to be spliced are peeled and threaded in only one operation using the Dextra thread rolling machine.

The machine must be operated by suitably trained staff in accordance with Dextra operating instruction.

The parts are screwed together by hand and tightened using a stilson or pipe wrench.

Peeling

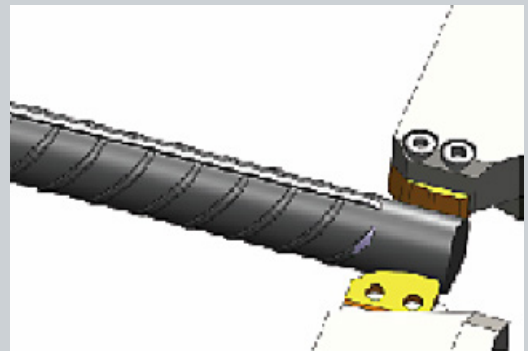

Roll threading

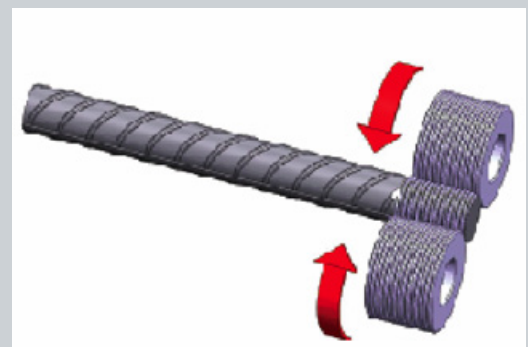

4.1 Standard range

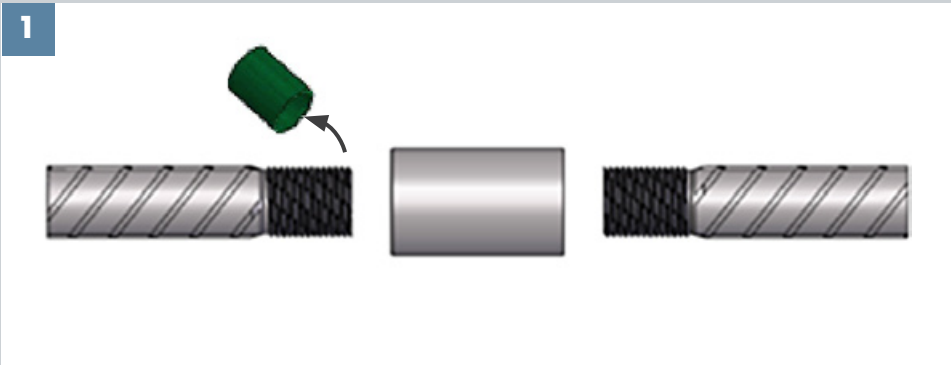

Remove the plastic protections from the bar threads.

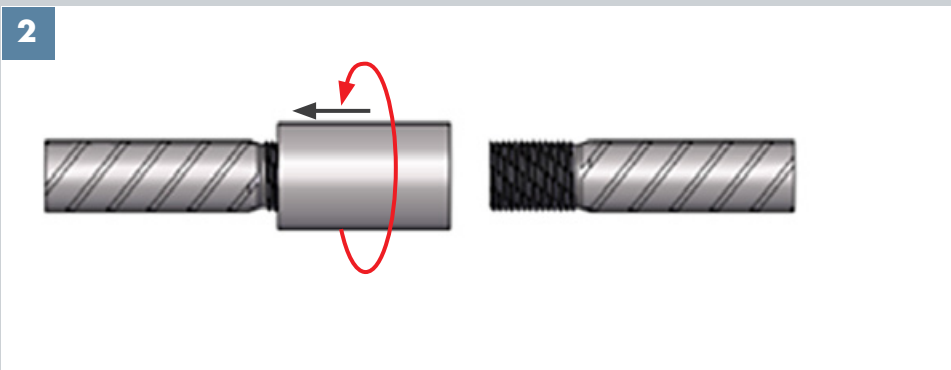

Screw the coupler onto the first bar.

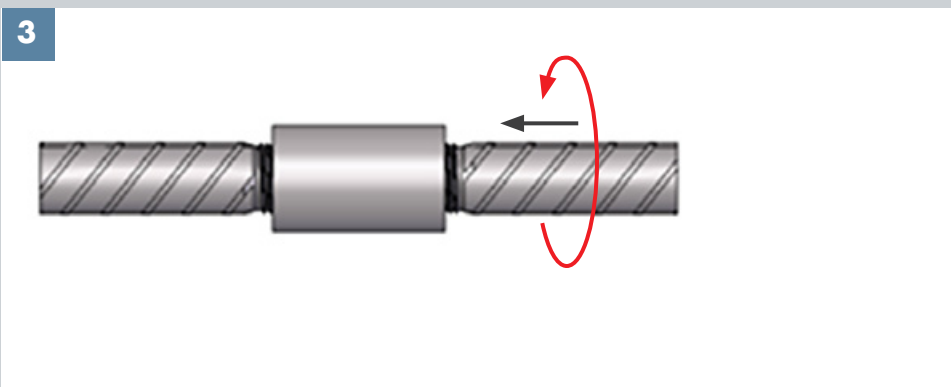

Join the bars by rotating the continuation bar into the coupler.

Use a stilson or pipe wrench to tighten on the continuation bar.

4.2 Positional range with hexagonal lock nut

1

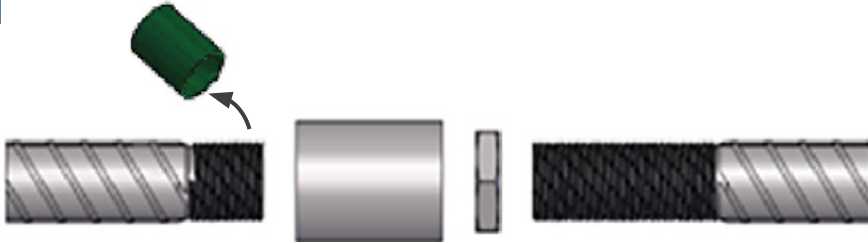

Remove the plastic protections from the bar threads.

2

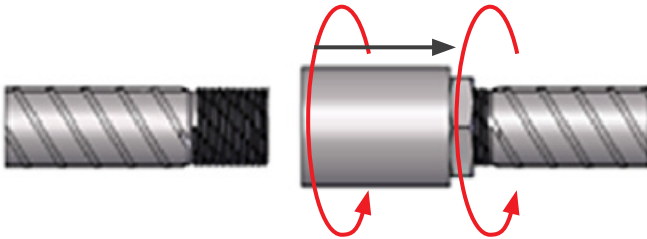

Screw the coupler and hexagonal lock nut onto the continuation bar.

3

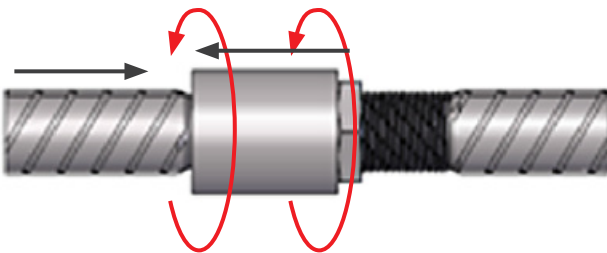

Put both bar ends in contact, and screw the coupler out of the continuation bar onto the first stage bar.

Use a stilson or pipe wrench to tighten the coupler and lock nut.

4.3 Positional range with round lock nut

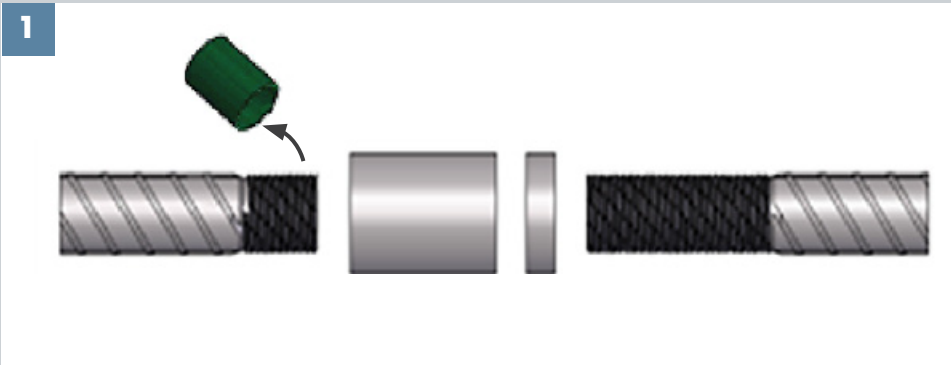

Remove the plastic protections from the bar threads.

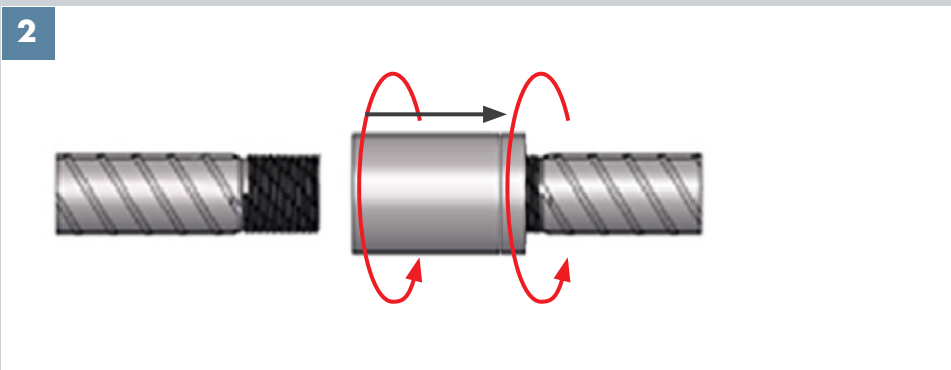

Screw the coupler and round lock nut onto the continuation bar.

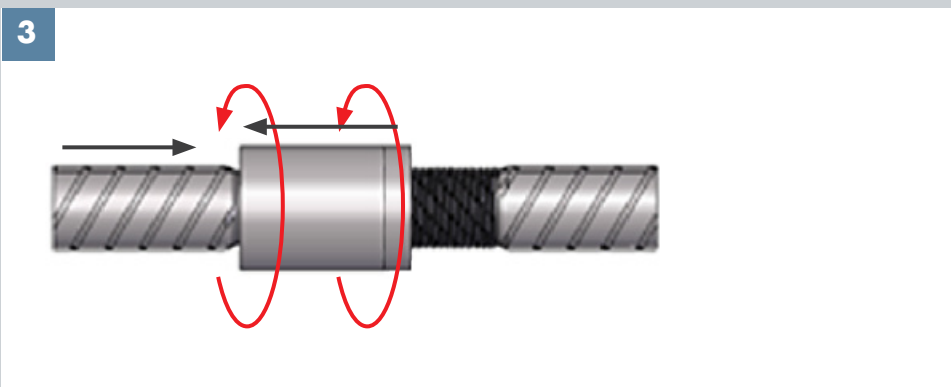

Put both bar ends in contact, and screw the coupler out of the continuation bar onto the first stage bar.

Use a stilson or pipe wrench to tighten the coupler and lock nut.

4.4 Caging range using hexagonal lock nut

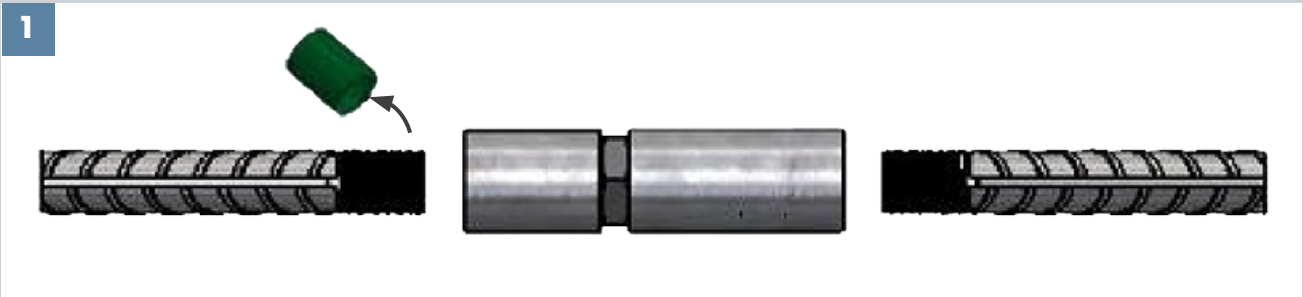

Remove the plastic protections from the bar threads.

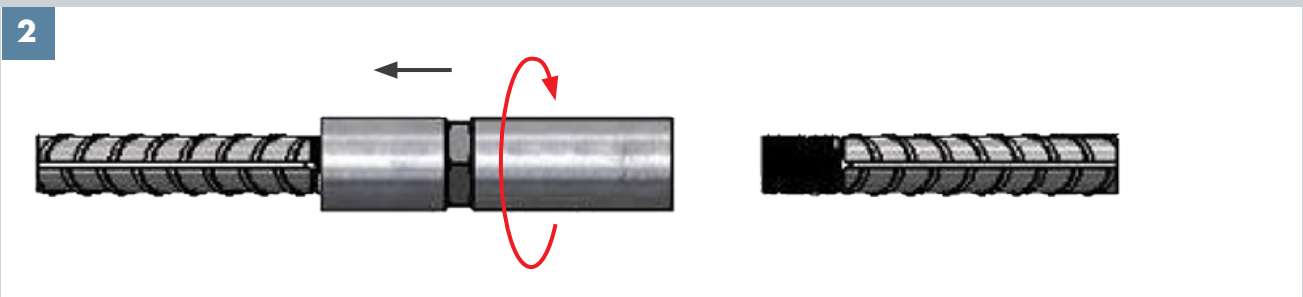

Screw the Caging assembly set onto the first bar.
(Preferably the top bar in case of vertical assemblies).

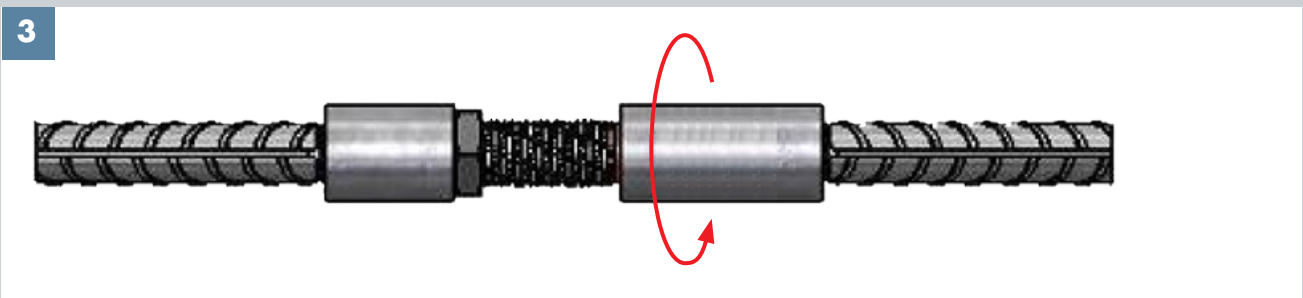

Put continuation bar end and the Caging stud in contact, and screw the Caging coupler of the Caging assembly set onto the continuation bar.

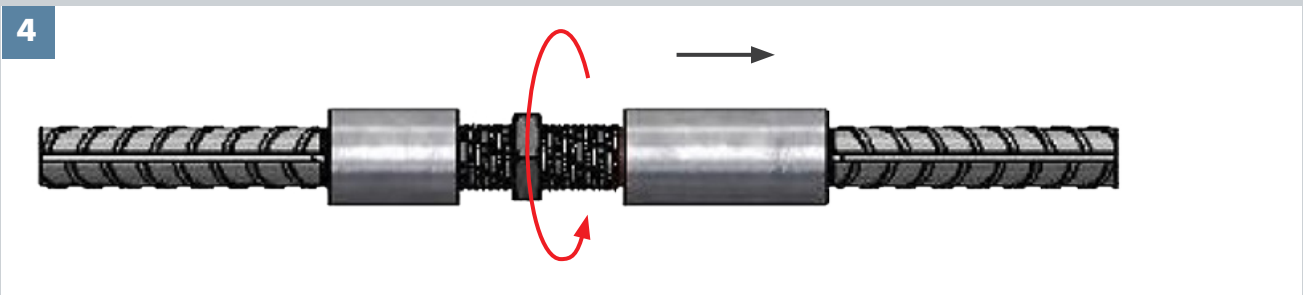

Screw the hexagonal lock-nut close to the Caging coupler.
Use a stilson or pipe wrench to tighten the female Caging stud, the Caging coupler and lock nut.

4.5 Caging range using round lock nut

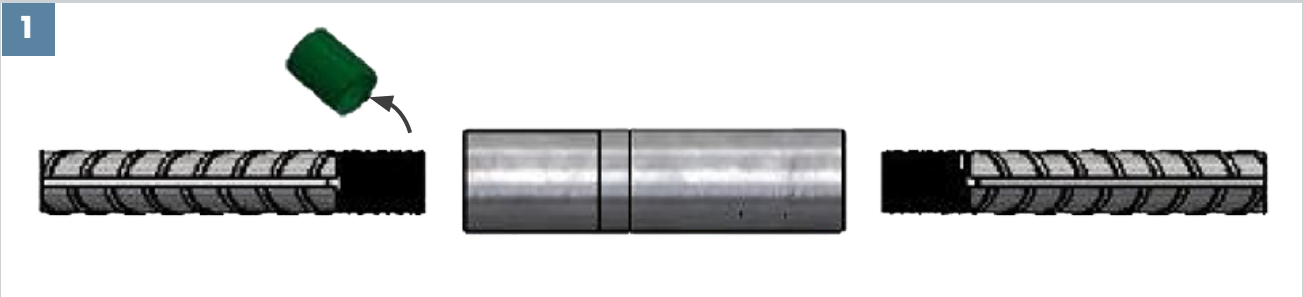

Remove the plastic protections from the bar threads.

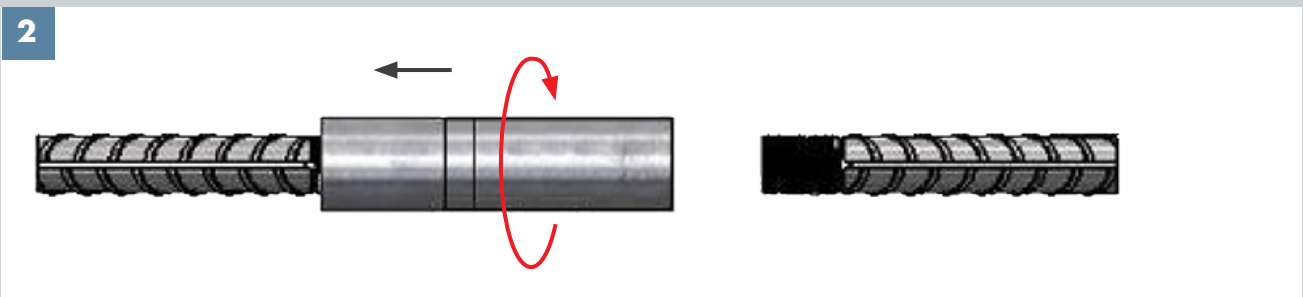

Screw the Caging assembly set onto the first bar.
(Preferably the top bar in case of vertical assemblies).

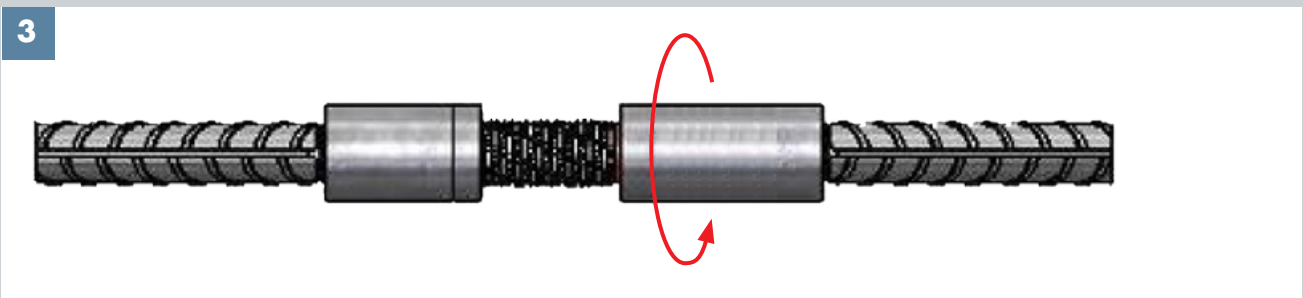

Put continuation bar end and the Caging stud in contact, and screw the Caging coupler of the Caging assembly set onto the continuation bar.

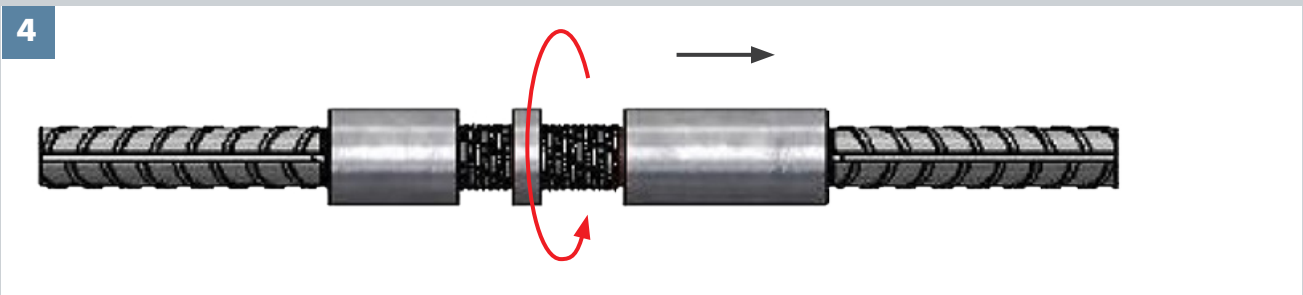

Screw the round lock-nut close to the Caging coupler.
Use a stilson or pipe wrench to tighten the female Caging stud, the Caging coupler and lock nut.

5 Safety Considerations

Couplers are supplied in wooden containers which have a maximum weight of 2000 kg and must be handled with appropriate lifting equipment. It is advisable to wear protective gloves during handling the containers, couplers and reinforcement; during coupler installation.

6 Product Testing and Evaluation

Dextra ROLLTEC Standard, Positional and Caging Couplers have been tested to satisfy the requirements of CARES Appendix TA1-B for Couplers with reinforcing bars to BS4449 Grade B500C and BS4449 Grade B500B. The testing comprised the following elements:

- Tensile Strength
- Permanent deformation in tension

7 Quality Assurance

Dextra ROLLTEC Standard, Positional and Caging Couplers are produced under an EN ISO 9001 quality management system certified by CARES. The quality management system scheme monitors the production of the couplers and ensures that materials and geometry remain within the limits of this technical approval.

The products are also subject to a programme of periodic testing.

8 Building Regulations

8.1 The Building Regulations (England and Wales)

Structure, Approved Document A

Dextra ROLLTEC Standard, Positional and Caging Couplers, when used in EC2 based designs using the data contained within this technical approval, satisfy the relevant requirements of The Building Regulations (England and Wales), Approved Document A.

Materials and Workmanship, Approved Document

This technical approval gives assurance that the Dextra ROLLTEC Standard, Positional and Caging Couplers comply with the material requirements of EC2.

8.2 The Building Regulations (Northern Ireland)

Materials and Workmanship

This technical approval gives assurance that Dextra ROLLTEC Standard, Positional and Caging Couplers comply with the material requirements of EC2 by virtue of regulation 23, *Deemed to satisfy provisions regarding the fitness of materials and workmanship.*

8.3 The Building Standards (Scotland)

Fitness of Materials

This technical approval gives assurance that Dextra ROLLTEC Standard, Positional and Caging Couplers comply with the material requirements of EC2 by virtue of *Clause 0.8.*

Structure

Dextra ROLLTEC Standard, Positional and Caging Couplers, when used in EC2 based designs using the data contained within this technical approval, satisfy the requirements of *The Building Standards (Scotland) Clause 1.*



9 References

- BS4449: 2005: Steel for the reinforcement of concrete - Weldable reinforcing steel - Bar, coil and decoiled product - Specification.
- BS8110: Part 1: 1997: Structural Use of Concrete, Code of Practice for Design and Construction.
- BS EN 1992-1-1:2004 Eurocode 2 Design of concrete structures - General rules for buildings.
- BS EN ISO 9001: Quality management systems - Requirements.
- CARES Appendix TA1-B; Quality and Operations Schedule for the Technical Approval of Couplers for Reinforcing Steel and Reinforcement Anchors For BS8110 and EN1992-1-1 Applications for Static Loading in Tension or Tension and Compression.

10 Conditions

1. The quality of the materials and method of manufacture have been examined by CARES and found to be satisfactory. This technical approval will remain valid provided that:
 - a) The product design and specification are unchanged.
 - b) The materials, method of manufacture and location are unchanged.
 - c) The manufacturer complies with CARES regulations for Technical Approvals.
 - d) The manufacturer holds a valid CARES Certificate of Product Assessment.
 - e) The product is installed and used as described in this report.
2. CARES make no representation as to the presence or absence of patent rights subsisting in the product and/or the legal right of Dextra to market the product.
3. Any references to standards, codes or legislation are those which are in force at the date of this certificate.
4. Any recommendations relating to the safe use of this product are the minimum standards required when the product is used. These requirements do not purport to satisfy the requirements of the Health and Safety at Work etc Act 1974 or any other relevant safety legislation.
5. CARES does not accept any responsibility for any loss or injury arising as a direct or indirect result of the use of this product.
6. This Technical Approval Report should be read in conjunction with CARES Certificate of Product Assessment No 5042. Confirmation that this technical approval is current can be obtained from UK CARES.





Electronic Copy www.ukcares.com



UK CARES

Pembroke House
21 Pembroke Road
Sevenoaks
Kent TN13 1XR

Phone: +44(0)1732 450000
Fax: +44(0)1732 455917
E-mail: general@ukcares.com
URL: www.ukcares.com

**Independent Product Assessments
for the Construction Industry**

Copyright UK CARES ©