



DEXTRA MANUFACTURING CO., LTD.

247 Sarasin Road, Lumpini, Pathumwan

Bangkok, Thailand

www.dextragroup.com

DEXTRA MECHANICAL SPLICE SYSTEM

CSI Section:

03 21 00 – Reinforcing Steel

1.0 RECOGNITION

DEXTRA Mechanical Splice System recognized in this report has been evaluated for use as mechanical splices for deformed steel reinforcing bars (rebar) in reinforced concrete structural members. The structural properties of the DEXTRA Mechanical Splice System comply with the intent of the provisions of the following codes and regulations:

- 2018, 2015, 2012, and 2009 International Building Code (IBC®)
- 2018, 2015, 2012, and 2009 International Residential Code (IRC®)
- 2020 City of Los Angeles Building Code (LABC) – attached Supplement
- 2020 City of Los Angeles Residential Code (LARC) – attached Supplement
- 2019 California Building Code (CBC) – attached Supplement
- 2019 California Residential Code (CRC) – attached Supplement
- 2013 Abu Dhabi International Building Code (ADIBC) – attached Supplement

2.0 LIMITATIONS

Use of the DEXTRA Mechanical Splice System recognized in this report is subject to the following limitations:

2.1 DEXTRA Mechanical Splice System shall be installed in accordance with the applicable code, the manufacturer’s instructions, and this report. Where conflicts occur, the more restrictive governs.

2.2 Splice locations shall comply with applicable IBC requirements and be noted on plans approved by the building official.

2.3 Special inspections shall be provided in accordance with Section 3.4 of this report.

2.4 Under the 2018 IBC, for structures regulated by Chapter 18 of ACI 318-14 (as required by 2018 IBC Section 1905.1), to splice deformed reinforcing bars resisting earthquake-

induced flexure, axial force, or both, in special moment frames, special structural walls, and all components of special structural walls including coupling beams and wall piers, with the DEXTRA Mechanical Splice System, mill certificates of reinforcing bars shall be submitted to the building official as evidence that the steel reinforcing bars comply with ACI 318-14 Section 20.2.2.5.

2.5 Under the 2015 IBC, for structures regulated by Chapter 18 of ACI 318-14 (as required by 2015 IBC Section 1905.1), to splice deformed reinforcing bars resisting earthquake-induced flexure, axial force, or both, in special moment frames, special structural walls, and all components of special structural walls including coupling beams and wall piers, with the DEXTRA Mechanical Splice System, mill certificates of reinforcing bars shall be submitted to the building official as evidence that the steel reinforcing bars comply with ACI 318-14 Section 20.2.2.5.

2.6 Under the 2012 IBC, for structures regulated by Chapter 21 of ACI 318-11 (as required by 2012 IBC Section 1905.1), to splice deformed reinforcing bars resisting earthquake-induced flexure, axial force, or both, in special moment frames, special structural walls, and all components of special structural walls including coupling beams and wall piers, with the DEXTRA Mechanical Splice System, mill certificates of reinforcing bars shall be submitted to the building official as evidence that the steel reinforcing bars comply with ACI 318-11 Section 21.1.5.2.

2.7 Under the 2009 IBC, for structures regulated by Chapter 21 of ACI 318-08 (as required by 2009 IBC Section 1908.1), to splice deformed reinforcing bars resisting earthquake-induced flexural and axial forces in frame members, structural walls, and coupling beams, with the DEXTRA Mechanical Splice System, mill certificates of reinforcing bars shall be submitted to the building official as evidence that the steel reinforcing bars comply with ACI 318-08 Section 21.1.5.2.

2.8 DEXTRA Mechanical Splice System recognized in this report is produced in Bangkok, Thailand.

3.0 PRODUCT USE

3.1 General: The DEXTRA Mechanical Splice System is used to mechanically splice deformed steel reinforcing bars (rebar) installed in concrete structural members. The splices conform to ACI 318-19 and -14 Section 25.5.7.1 and 18.2.7 (ACI 318-11 and -08 Sections 12.14.3 and 21.1.6), for use as tension and compression mechanical splices for deformed steel reinforcing bar (rebar). The DEXTRA Mechanical Splice System complies with both Type 1 and Type 2 mechanical splice requirements in accordance with ACI 318

The product described in this Uniform Evaluation Service (UES) Report has been evaluated as an alternative material, design or method of construction in order to satisfy and comply with the intent of the provision of the code, as noted in this report, and for at least equivalence to that prescribed in the code in quality, strength, effectiveness, fire resistance, durability and safety, as applicable, in accordance with IBC Section 104.11. This document shall only be reproduced in its entirety.





Originally Issued: 06/05/2020

Revision: 08/30/2021

Valid Through: 06/30/2022

-19 and -14 Section 18.2.7.1 (ACI 318-11 and -08 Section 21.1.6.1) as illustrated in Tables 1 through 4 of this report and consists of:

- **BARTEC** Standard splice, Position splice, and Form Fixer coupler
- **ROLLTEC** Standard splice, Position type B splice, Position type C splice, Caging splice, and Form Fixer coupler
- **UNITEC** Mechanical splice

3.2 Design: The DEXTRA Mechanical Splice System shall be installed in accordance with the IBC, ACI 318, this evaluation report, and the manufacturer's published installation instructions. Where conflicts occur, the more restrictive shall govern. Splice locations shall be detailed on the construction documents and approved by the building official, in accordance with IBC Section 1901.5.

The concrete cover and spacing shall be in accordance with IBC Chapters 7 and 19, ACI 318-19 Section 20.5.1 and ACI 318-14 Section 20.6.1 (ACI 318-11 and -08 Section 7.7) and shall be measured from the outer surface of the splice system or as defined by the registered design professional. Type 2 mechanical splices are permitted in any location within a member as allowed by the IBC, IRC, and ACI 318 in all seismic design categories.

3.3 Installation: Installation instructions are supplied with the product and/or are available on the Dextra website (www.dextragroup.com) and as described below.

3.3.1 BARTEC and ROLLTEC Standard Splice Type A: Rebar splices are accomplished by the use of a standard female coupler matching the thread size made on the bars. The pre-threaded bar end thread length equals one-half the length of the coupler. The continuation bar shall be rotated in order to achieve the connection. The connection is complete when no exposed threads are observed on either rebar.

3.3.2 BARTEC and ROLLTEC Position Splice Type B: These splices are designed to be used when it would be a burden to rotate both bars. The connecting bar has an extended thread onto the ribs of the bar, thereby enabling the coupler to be fully screwed onto it. Next, the bars are butted end to end. The coupler is then unscrewed from the connecting bar onto the second bar to accomplish the connection, with no exposed threads on the second bar.

3.3.3 ROLLTEC Position Splice Type C: This splice is a Type B connection where the threads have been further extended to accommodate a lock nut on one bar. These splices are intended when the second bar is bent and needs to be oriented in a specific direction. After two bars are positioned and threaded to the coupler, the lock nut is set.

3.3.4 BARTEC and ROLLTEC Form Fixer Coupler: These devices are standard couplers fitted with a square flange that can be nailed to a wooden formwork to facilitate the positioning of reinforcement. Installation shall be in accordance with Section 3.3.1 of this report.

3.3.5 ROLLTEC Caging Splice: This splicing system is designed to be used when the bars cannot be end-buttet. The system is constituted of three pieces preassembled together: a caging stud, a long caging coupler, and a lock-nut. The end of the caging stud bears a female thread that fits on one bar.

3.3.6 Unitec Standard Splice: This splice is used to connect two reinforcing bars mechanically. The Unitec coupler is inserted over the end of the first reinforcing bar until contact with the center spring pin. The bolts are then tightened from center to outside first by hand-tightening with a manual wrench for pre-locking, and then tightening with a pneumatic wrench until the heads shear off. The Unitec coupler is then inserted into the second reinforcing bar until contact with the center spring pin. Repeat the bolt installation as described above. The installation shall be in accordance with the Assembly Instructions for UNITEC provided by Dextra.

3.4 Special Inspection

3.4.1 General: Special inspection of the DEXTRA Mechanical Splice System shall be provided at the job site as required by Section 1705 of the 2021, 2018, 2015, and 2012 IBC (Section 1704 of the 2009 IBC). In addition to verifying placement of reinforcing bar splices, the special inspector shall verify the grade and size of the reinforcing bars, coupler identification, reinforcing bar embedment length to couplers, the position of couplers, placement of reinforcing bar splices, as well as installation of the couplers to the reinforcing bars. Bar alignment with the coupler shall be within ¼ inch per 12 inches (5 mm per 250 mm).

4.0 PRODUCT DESCRIPTION

4.1 General

4.1.1 BARTEC: BARTEC is a parallel threaded mechanical splicing system designed for the connection of concrete reinforcing bars. The splice system is made by enlarging the reinforcing bar ends by cold upsetting prior to threading. Figures 1, 2, and 4 of this report illustrate the BARTEC Standard Splice, Position Splice, and Form Fixer assembly, accordingly. The BARTEC couplers with dimensions shown in Table 1 of this report are designed to mechanically join No. 4 through No. 18 and 38 mm reinforcing bars in accordance with:

- ASTM A615 Grades 60 or
- ASTM A706 Grades 60.



The bar end preparation shall be in accordance with the Bar End Preparation Quality Manual (BEPQM) for BARTEC provided by Dextra.

4.1.2 ROLLTEC: ROLLTEC is a rolled parallel threaded mechanical splicing system. The splice system requires peeling out the rebar ribs and rolling a thread at the end of the bar. Figures 1 to 6 of this report illustrate the ROLLTEC Standard Splice, Position Splice type B, Position Splice type C, Form Fixer assembly, and Caging splice. The ROLLTEC couplers with dimensions shown in Tables 2 and 3 of this report are designed to mechanically join:

- No. 4 through No.11, 38 mm, and 40 mm reinforcing bars in accordance with:
 - ASTM A615 Grade 60 and 80; or
 - ASTM A706 Grade 60 and 80; or
 - ISO 6935-2 Grade B500B
- No.14 and 18 reinforcing bars in accordance with
 - ASTM A615 Grades 60; or
 - ASTM A706 Grades 60

The bar end preparation shall be in accordance with the Bar End Preparation Quality Manual (BEPQM) for ROLLTEC provided by Dextra.

4.1.3 UNITEC: The UNITEC couplers consist of a sleeve that is fitted with one longitudinal row of radial bolts through its wall thickness, and longitudinal studs inside its inner cavity, opposite to the bolts. One or both rebars are inserted into the coupler and the bolts are tightened until their heads shear off. Figure 7 of this report illustrates the UNITEC Splice Assembly. The UNITEC couplers with dimensions shown in Table 4 of this report are designed to mechanically join No. 4 through No. 14 reinforcing bars in accordance with:

- ASTM A615 Grades 60, 75, or 80; or
- ASTM A706 Grades 60 or 80 or
- ISO 6935-2 Grade B500B

4.2 Couplers

4.2.1 BARTEC: The BARTEC couplers are formed from steel complying with GB/T 699 grade 20 and equivalent to JIS 4051 Grade S20C or ASTM A576 grade 1020, or GB/T 699 Grade 45 or GB/T 8162 Grade 45 and equivalent to JIS 4051 Grade S45C or ASTM A519 Grade 1045.

4.2.2 ROLLTEC: The ROLLTEC couplers and Caging couplers are formed from steel complying with GB/T 699 Grade 45 or GB/T 8162 Grade 45 and equivalent to JIS 4051 Grade S45C, or ASTM A519 Grade 1045. The caging studs are formed from steel complying with JIS G 4053 Grade SCM440 and equivalent to ISO 683-2 Grade 42 CrMo4, GB/T 3077 Grade 42 CrMo, or ASTM A322 Grades 4140

and 4142. The minimum yield and tensile strength values of the caging studs are 700 MPa (101.5 ksi) and 850 MPa (123.3 ksi), respectively.

4.2.3 UNITEC: The UNITEC couplers are formed from steel complying with GB/T 8162 Grade 45 and equivalent to JIS 4051 Grade S45C. The couplers conform to the requirements specified for ASTM A519 or SAE J403 Grade 1045. Figure 2 of this report illustrates the couplers.

5.0 IDENTIFICATION

All couplers and splices are packaged with a label bearing the manufacturer's name (Dextra Manufacturing Co., Ltd.) or brand name, address, model, and size and the IAPMO Uniform ES Mark of Conformity, and the Evaluation Report Number (ER-702) to identify the products recognized in this report. Each DEXTRA coupler is permanently stamped/labeled with the catalog number, size, heat number, Type 2 designation. The following Mark of Conformity shall be used as shown below:

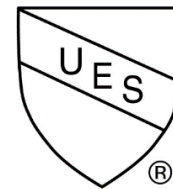

IAPMO UES ER-702

6.0 EVIDENCE SUBMITTED

6.1 Data submitted in accordance with the ICC-ES Acceptance Criteria for Mechanical Connector Systems for Steel Reinforcing Bars (AC133), approved August 2019.

6.2 Test reports submitted are from laboratories in compliance with ISO/IEC 17025.

7.0 STATEMENT OF RECOGNITION:

This report describes the results of research completed by the IAPMO Uniform Evaluation Service on DEXTRA Mechanical Splice System to assess its conformance to the codes listed in Section 1.0 and serves as documentation of the product certification. The products are manufactured at the location noted in Section 2.8 of this report under a quality control program with periodic inspections under the supervision of IAPMO UES.

For additional information about this evaluation report please visit www.uniform-es.org or email at info@uniform-es.org



TABLE 1 – Dimensions of Bartec Mechanical Splicing System (Standard, Position, and Form Fixer)¹

MODEL DESIGNATION	REINFORCING STEEL		D (inches)	L (inches)	A (inches)	THREAD DIMENSIONS ²
	Nominal Size	Equivalent Metric diameter (mm)				
BF12	#4	13	13/16	1 1/8	2 3/8	M14x2.0
BF16	#5	16	1	1 3/4	2 3/8	M20x2.5
BF20	#6	19	1 1/4	2 1/16	2 3/8	M24x3.0
BF22	#7	22	1 9/16	2 5/8	2 3/8	M27x3.0
BF25	#8	25	1 9/16	2 5/8	2 3/8	M30x3.5
BF28	#9	29	1 3/4	2 13/16	2 15/16	M33x3.5
BF#10	#10	32	1 7/8	3 1/16	2 15/16	M36x3.0
BF#11	#11	36	2 3/8	3 3/8	2 15/16	M39x4.0
B38	#12	38	2 7/16	3 1/2	N/A ³	M42x4.5
BF43	#14	43	2 3/4	3 13/16	N/A ³	M45x3.5

For SI: 1 inch = 25.4 mm

¹ Coupler dimensions in Tables 1 and 2 and as shown in Figures 1 through 4 are nominal dimensions

² The two values after the letter "M" are the nominal diameter in mm and the thread spacing in mm.

³ N/A signifies that the Form Fixer Couplers are not available in the noted sizes.

TABLE 2 – Dimensions of Rolltec Mechanical Splicing System (Standard, Position Type B, Position Type C and Form Fixer)¹

MODEL DESIGNATION	REINFORCING STEEL		D (inches)	L (inches)	T (inches)	A (inches)	THREAD DIMENSIONS ²
	Nominal Size	Equivalent Metric diameter (mm)					
RS12	#4	13	3/4	1 1/2	3/8	2 3/8	M13x1.5
RS#5	#5	16	1	1 7/8	3/8	2 3/8	M16x2.0
RS19	#6	19	1 1/4	2 3/8	3/8	2 3/8	M20x2.5
RS#7	#7	22	1 3/8	2 1/2	3/8	2 3/8	M22x2.5
RS24	#8	25	1 5/8	2 3/4	1/2	2 3/8	M25x2.5
RS28	#9	29	1 3/4	2 3/4	1/2	3	M29x3.0
RS#10	#10	32	2	3 1/2	1/2	3	M33x3.0
RS35	#11	36	2 1/4	3 3/8	5/8	3	M36x3.0
RS38	#12	38	2 3/8	3 3/4	11/16	N/A ³	M39x3.0
RS40	-	40	2 1/2	4 1/8	5/8	N/A ³	M41x3.0
RS43	#14	43	2 3/4	5	7/8	N/A ³	M43x3.0
RS57	#18	57	3 3/4	5 1/2	7/8	N/A ³	M57x4.0

For SI: 1 inch = 25.4 mm

¹ Coupler dimensions in Tables 1 and 2 and as shown in Figures 1 through 4 are nominal dimensions

² The two values after the letter "M" are the nominal diameter in mm and the thread spacing in mm.

³ N/A signifies that the Form Fixer Couplers are not available in the noted sizes.

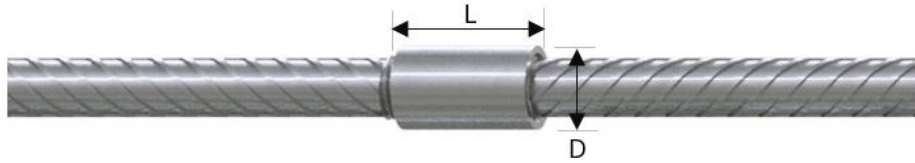

FIGURE 1 – INSTALLED BARTEC AND ROLLTEC COUPLER (STANDARD SPLICE)

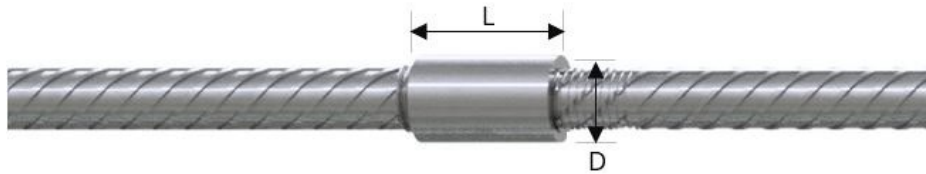

FIGURE 2 – INSTALLED BARTEC AND ROLLTEC COUPLER (POSITION TYPE B SPLICE)

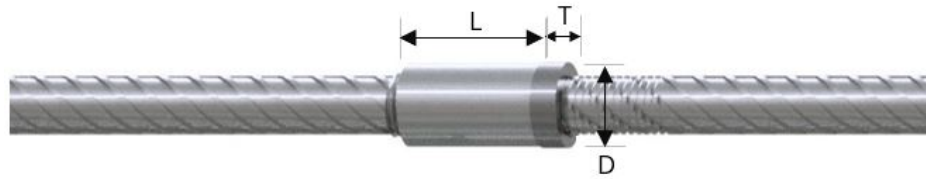

FIGURE 3 – INSTALLED ROLLTEC COUPLER (POSITION TYPE C SPLICE)

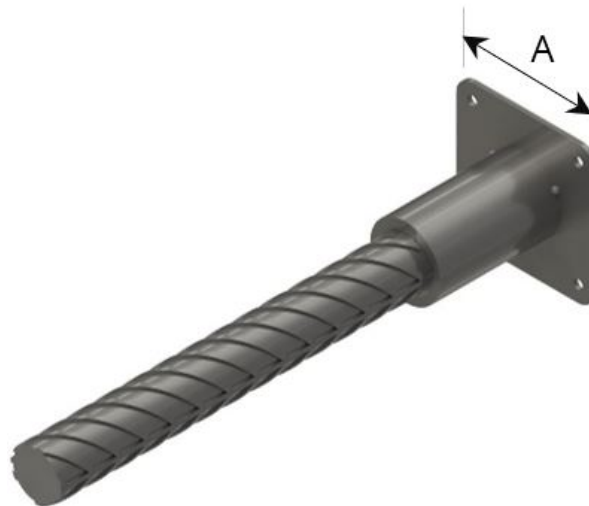

FIGURE 4 – INSTALLED FORM FIXER COUPLER



TABLE 3 – Dimensions of Rolltec Mechanical Splicing System (Caging Coupler)¹

MODEL DESIGNATION	REINFORCING STEEL		D (inches)	L max (inches)	THREAD DIMENSIONS ²	b max
	Nominal Size	Equivalent Metric diameter (mm)				
RS#6	#6	19	1 ¼	8	M20x2.5	2 1/16
RS#7	#7	22	1 3/8	8 5/8	M22x2.5	2 1/4
RS24	#8	25	1 5/8	9 3/8	M25x2.5	2 3/8
RS28	#9	29	1 ¾	9 3/4	M29x3.0	2 5/8
RS#10	#10	32	2	12 1/8	M33x3.0	2 3/4
RS35	#11	36	2 ¼	12 3/8	M36x3.0	3 5/16
RS40	-	40	2 ½	14 3/8	M41x3.0	3 13/16
RS43	#14	43	2 ¾	17 1/8	M43x3.0	4 3/8
RS57	#18	57	3 ¾	19 5/8	M57x4.0	5 5/16

For SI: 1 inch = 25.4 mm

¹ Coupler dimensions in Table 3 as shown in Figures 5 and 6 are nominal dimensions

² The two values after the letter "M" are the nominal diameter in mm and the thread spacing in mm.

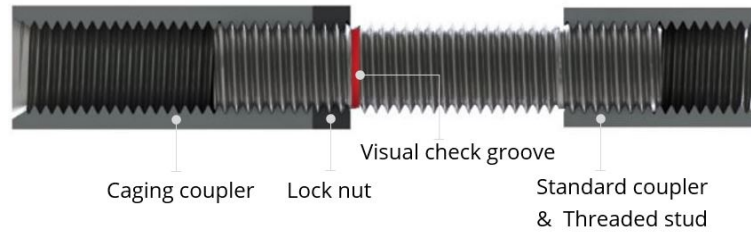

FIGURE 5 – ROLLTEC CAGING SET

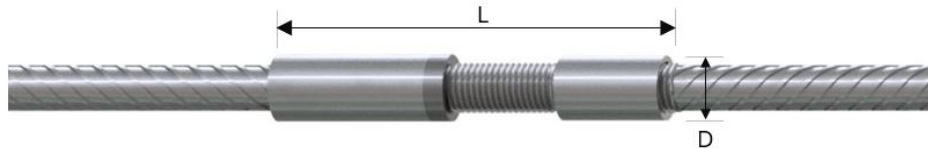

FIGURE 6 – ROLLTEC CAGING SPLICE

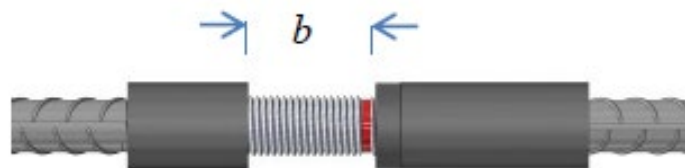

FIGURE 7 – ROLLTEC CAGING LENGTH ALLOWANCE



TABLE 4 – Dimension of Unitec Couplers

Bar Size (US)	Model	Coupler dimensions				Bolt size	Total Number of Bolts
		Outside dimension (D)		Length (L)			
		(mm)	(in)	(mm)	(in)		
#4	Unitec #4-12	48	1 7/8	140	5 1/2	M12	6
#5	Unitec #5-14	48	1 7/8	140	5 1/2	M12	6
#6	Unitec #6-20	52	2 1/16	200	7 7/8	M12	8
#7	Unitec #7-22	59	2 1/4	240	9 1/2	M16	8
#8	Unitec #8-25	62	2 1/2	240	9 1/2	M16	8
#9	Unitec #9-28	76	3	220	8 5/8	M20	6
#10	Unitec #10-32	83	3 1/4	280	11	M20	8
#11	Unitec #11-36	89	3 1/2	360	14 1/8	M20	10
#14	Unitec #14-43	95	3 3/4	555	21 7/8	M20	16

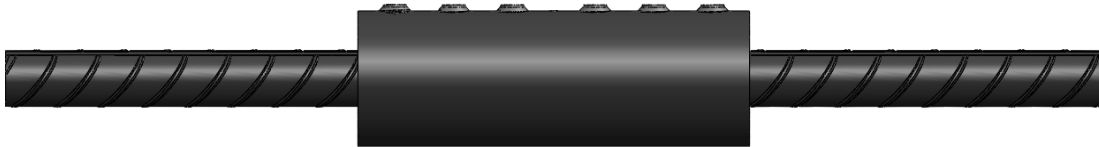

FIGURE 8 – UNITEC STANDARD SPLICE SYSTEM

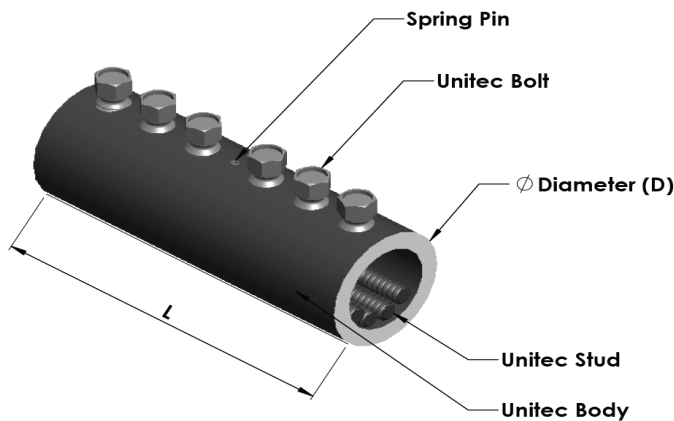

FIGURE 9 – UNITEC COUPLER DETAILS



CITY OF LOS ANGELES SUPPLEMENT

DEXTRA MANUFACTURING CO., LTD.
247 Sarasin Road, Lumpini, Pathumwan
Bangkok, Thailand
www.dextragroup.com

DEXTRA MECHANICAL SPLICE SYSTEM

CSI Section:

03 21 00 – Reinforcing Steel

1.0 RECOGNITION

The DEXTRA Mechanical Splice System described in ER-702 and this supplemental report has been evaluated for use as mechanical splices for deformed steel reinforcing bars (rebar) in reinforced concrete structural members. The DEXTRA Mechanical Splice System has been evaluated for structural performance properties, subject to the requirements in ER-702 and this supplemental report. The DEXTRA Mechanical Splice System was evaluated for compliance with the following codes and regulations:

- 2020 City of Los Angeles Building Code (LABC)
- 2020 City of Los Angeles Residential Code (LARC)

2.0 LIMITATIONS

Use of the DEXTRA Mechanical Splice System recognized in this supplement is subject to the following limitations:

2.1 Continuous special inspections of the DEXTRA Mechanical Splice System during installation shall be provided by Registered Deputy Inspectors as required by Section 1705 of the LABC. The Registered Deputy Inspector shall verify the following: hardware and equipment; cleaning and condition of the bars in accordance with the specifications and the applicable code; and the installation procedures comply with the specifications and the manufacturer's published installation instructions.

2.2 The fabricator of the steel couplers shall be required to maintain a detailed procedure for material control and suitable procedures and records attesting that the specified coupler has been furnished. The applicable splice designation (Type 1 or Type 2) or coating, as applicable, shall be included in each packaging assembly prior to shipment from the fabricator's plant. The fabricator's identification mark designation shall be established and on record prior to fabrication. Couplers that are not identifiable from marking and test records shall be tested to determine conformity to this report. The fabricator shall furnish an affidavit of compliance and test data shall be provided upon request.

2.3 The DEXTRA Mechanical Splice System shall be selected at the job site by the Registered Deputy Inspector or

by the building inspector and shall be tested by an approved testing agency in accordance with Section 1703 of the LABC. The test shall be conducted on each different rebar size and the frequency of tests shall be as follows: one out of the first ten splices; one out of the next ninety splices; one out of the next one hundred splices. The splice shall develop in tension or compression, as required, at least 125 percent of the specified yield strength of the bar in accordance with Section 25.5.7.1 of ACI 318-14. For Type 2 splices, the splice shall develop at least 100 percent of the specified tensile strength of the steel reinforcing bar.

For Type 2 splices only, if failure of the tested splice should occur prior to obtaining the 125-percent of the specified yield strength and the 100-percent of the specified tensile strength, then 25-percent of all couplers shall be tested for both specified yield strength and specified tensile strength. If failure of the tested Type 2 splice occurs with testing of the 25-percent requirement, as stated above, then all couplers shall be rejected.

2.4 Minimum concrete cover and spacing between bars or sleeves shall be provided in accordance with Section 1808.8.2 of the LABC.

2.5 The DEXTRA Mechanical Splice System shall be installed in accordance with the applicable code, manufacturer's installation instructions, and this supplement. A copy of the manufacturer's installation instructions or specifications shall be available on-site for all Registered Deputy Inspectors.

2.6 Splice locations shall be noted on the plans approved by the building official.

2.7 Only qualified operators completely familiar with the installation procedures and specifications shall perform the splicing.

2.8 This supplement expires concurrently with ER-702.

3.0 CONCLUSIONS

The DEXTRA Mechanical Splice System described in ER-702, complies with LABC and LARC, given the design and installation is in accordance with the 2018 International Building Code® (IBC) and 2019 California Building Code (CBC), or 2018 International Residential Code® (IRC) and 2019 California Residential Code (CRC). Additional requirements of the LABC Chapters 16, 17, 18, and 19 shall apply.

For additional information about this evaluation report please visit www.uniform-es.org or email at info@uniform-es.org



CALIFORNIA BUILDING CODE SUPPLEMENT

DEXTRA MANUFACTURING CO., LTD.
247 Sarasin Road, Lumpini, Pathumwan
Bangkok, Thailand
www.dextragroup.com

DEXTRA MECHANICAL SPLICE SYSTEM

CSI Section:

03 21 00 Reinforced Steel

1.0 RECOGNITION

The DEXTRA Mechanical Splice System described in ER-702 and this CBC and CRC supplemental report has been evaluated for use as mechanical splices for deformed steel reinforcing bars (rebar) in reinforced concrete structural members. The DEXTRA Mechanical Splice System has been evaluated for structural performance properties, subject to the requirements in ER-702 and this CBC and CRC supplemental report. The DEXTRA Mechanical Splice System was evaluated for compliance with the following codes and regulations:

- 2019 California Building Code (CBC)
- 2019 California Residential Code (CRC)

2.0 LIMITATIONS

Use of the DEXTRA Mechanical Splice System recognized in this supplement is subject to the following limitations in addition to the limitations shown in ER-702:

2.1 Calculations and specifications verifying compliance with the DEXTRA Mechanical Splice System shall be submitted to the building official for approval at the time of permit application. The DEXTRA Mechanical Splice System calculations shall be prepared by a Civil or Structural Engineer registered in the State of California.

2.2 Periodic special inspection shall be provided in accordance with Section 1705.3 or 1705A.3 (DSA and OSHPD) of the CBC during installations of the DEXTRA Mechanical Splice System.

2.3 Tests of reinforcing bars shall be provided in accordance with CBC Section 1909.2.4, 1910.2.2, or 1910A.2, as applicable.

2.4 The DEXTRA Mechanical Splice System shall be installed in accordance with the CBC or CRC, as applicable, manufacturer's installation instructions, and this supplement. A copy of the manufacturer's installation instructions shall be available on-site for the building official and special

inspector. Where conflicts occur, the more restrictive shall govern.

2.5 For work in accordance with CBC Chapter 19A (DSA and OSHPD), construction documents shall include the type and location of mechanical splices of reinforcement, as set forth in CBC Section 1901A.5.

2.6 For use in foundation walls, minimum concrete cover and spacing between bars or sleeves shall be provided in accordance with Section 1808.8.2 or 1808A.8.2 of the CBC. Concrete cover and spacing shall be measured from the outer surface of the DEXTRA Mechanical Splice System.

2.7 Type 2 mechanical splices shall be provided in accordance with CBC 1905A.1.10 for DSA and OSHPAD regulated structures.

2.8 This supplement expires concurrently with ER-702.

3.0 CONCLUSIONS

The DEXTRA Mechanical Splice System described in ER-702, complies with CBC and CRC, given the design and installation is in accordance with the 2018 International Building Code® (IBC) or 2018 International Residential Code® (IRC). Additional requirements of CBC Chapters 16, 17, 18 and 19 shall apply.

For additional information about this evaluation report please visit www.uniform-es.org or email us at info@uniform-es.org



ABU DHABI SUPPLEMENT

DEXTRA MANUFACTURING CO., LTD.

247 Sarasin Road, Lumpini, Pathumwan

Bangkok, Thailand

www.dextragroup.com

DEXTRA MECHANICAL SPLICE SYSTEM

CSI Section:

03 21 00 Reinforced Steel

1.0 RECOGNITION

The DEXTRA Mechanical Splice System described in ER-702 and this Abu Dhabi supplemental report has been evaluated for use as mechanical splices for deformed steel reinforcing bars (rebar) in reinforced concrete structural members. The DEXTRA Mechanical Splice System has been evaluated for structural performance properties, subject to the requirements in ER-702 and this Abu Dhabi supplemental report. The DEXTRA Mechanical Splice System were evaluated for compliance with the following codes and regulations:

- 2013 Abu Dhabi International Building Code (ADIBC)

2.0 LIMITATIONS

Use of the DEXTRA Mechanical Splice System recognized in this supplement is subject to the following limitations in addition to the limitations shown in ER-702:

2.1 The DEXTRA Mechanical Splice System described in ER-702, complies with Chapter 19 of the 2013 ADIBC, given the design and installation is in accordance with the 2009 International Building Code® (IBC).

2.2 The specified compressive strength of concrete, f'_c shall not be less than 24 MPa (3,480 psi), when used in special moment frames and special structural walls in accordance with Section 21.1.4.2 of Appendix L in the 2013 ADIBC.

2.3 For structures regulated by Chapter 21 of ACI 318-08, as required by Section 21.1.5.2 of Appendix L in the 2013 ADIBC, where the DEXTRA Mechanical Splice System is designed to resist earthquake-induced flexure and axial forces in frame members, structural walls, and coupling beams, mill certificates complying with ASTM A706M or BS EN4449 Class C, ASTM A615M Grades 280 and 420 or BS EN 4449 Class A or B reinforcement shall be submitted to the building official as evidence that the steel reinforcing bars are compliant.

2.4 Special inspection of the headed bars shall be provided at the jobsite as required by Sections 1704.4 and 1709.1 of the 2013 ADIBC. The special inspector is responsible for verifying identification of the headed deformed reinforcing bars and plates, grade and size of reinforcing bars, proper joining of reinforcing bars with the anchor plate heads as well as placement of the headed bars.

2.5 This supplement expires concurrently with ER-702.

3.0 CONCLUSIONS

The DEXTRA Mechanical Splice System described in ER-702, complies with ADIBC, given the design and installation is in accordance with the 2009 International Building Code® (IBC).

For additional information about this evaluation report please visit www.uniform-es.org or email us at info@uniform-es.org